

Intelligent DINRail Temperature Transmitter RTM5001



4 - 20 mADC and HART output options



Quick Response Time



Working Temperature: (-) 40 ~ 85°C



Auto. Compensation on Cold Junction Temp.

**Product
Datasheet**

ROCKSENSOR AT A GLANCE (ABOUT US)

Rocksensor is one of the global leaders specializing in Process Instrumentation, Research and Development and Designing of Industrial Automation Equipment. We provide highly precise pressure sensors and transmitters, flow metres, level transmitters and temperature transmitters with a prime focus to help our clients efficiently, safely and economically run complex industrial processes.

Rocksensor, headquartered in Switzerland, has its footprint in various geographical regions such as the US, Russia, South Korea, Italy, Germany, Singapore, Malaysia, Morocco, China, Taiwan, Australia, UAE, Brazil and India. Our clients come from some of the major industries such as Oil and Gas, Petrochemicals, Pharmaceuticals, FMCG, Automobiles, Water, Cement, Metal & Mining, and mainly from the Power Industry like Nuclear, Thermal, Hydro, and Solar.

Rocksensor deals in a wide range of highly accurate industrial automation instruments ensuring that even the complex industrial processes happen efficiently.

To fulfill the needs of our clients we make sure that our instruments work in even the harsh environmental conditions offering accurate recordings and communication.

We, at Rocksensor, believe in creating bonds that last a lifetime and create a success story for each and every client. Rocksensor aims to achieve a perfect fit in the global market landscape and establish our footprints across the globe.



Contents

1. Introduction	4
2. Salient Features	4
3. Components	5
4. Configuration	6
5. Electrical Diagram (with HART)	7
6. Electrical Diagram (without HART)	7
7. Connection with HART	8
8. Technical Parameters	9
9. Input type and transmission accuracy	10
10. Ordering Table	11

1. Introduction

RTM5001 DIN Mounted Temperature Transmitter is loop powered Programmable thermocouple, RTD temperature input, with input-output-power isolated, transmitting the signal thermocouple, RTD sensor as analog signal output to various instruments or DCS, PLC, SCADA etc. control systems.

Isolated Temperature Transmitter DIN Rail Mounted Loop Powered Signal Isolator, Signal Converter.

2. Salient Features

- 1 input 1 output, 2 inputs 2 outputs
- Programmable thermocouple, RTD input
- Transmission accuracy (20°C): (0.2%FS+1) digit
- Temperature shift: 0.0075%FS/°C
- With auto. compensation on cold junction temperature
- Output signal: 4-20mA+HART
- DIN35mm rail mounting with pluggable terminals
- Size:121.2 x 108 x 13mm

Key Application Industries

- Cement
- Metal
- Pulp and Paper
- Textiles
- Chemicals
- Power
- Pharmaceutical
- Fertilizer
- Plastics and HVAC

3. Components

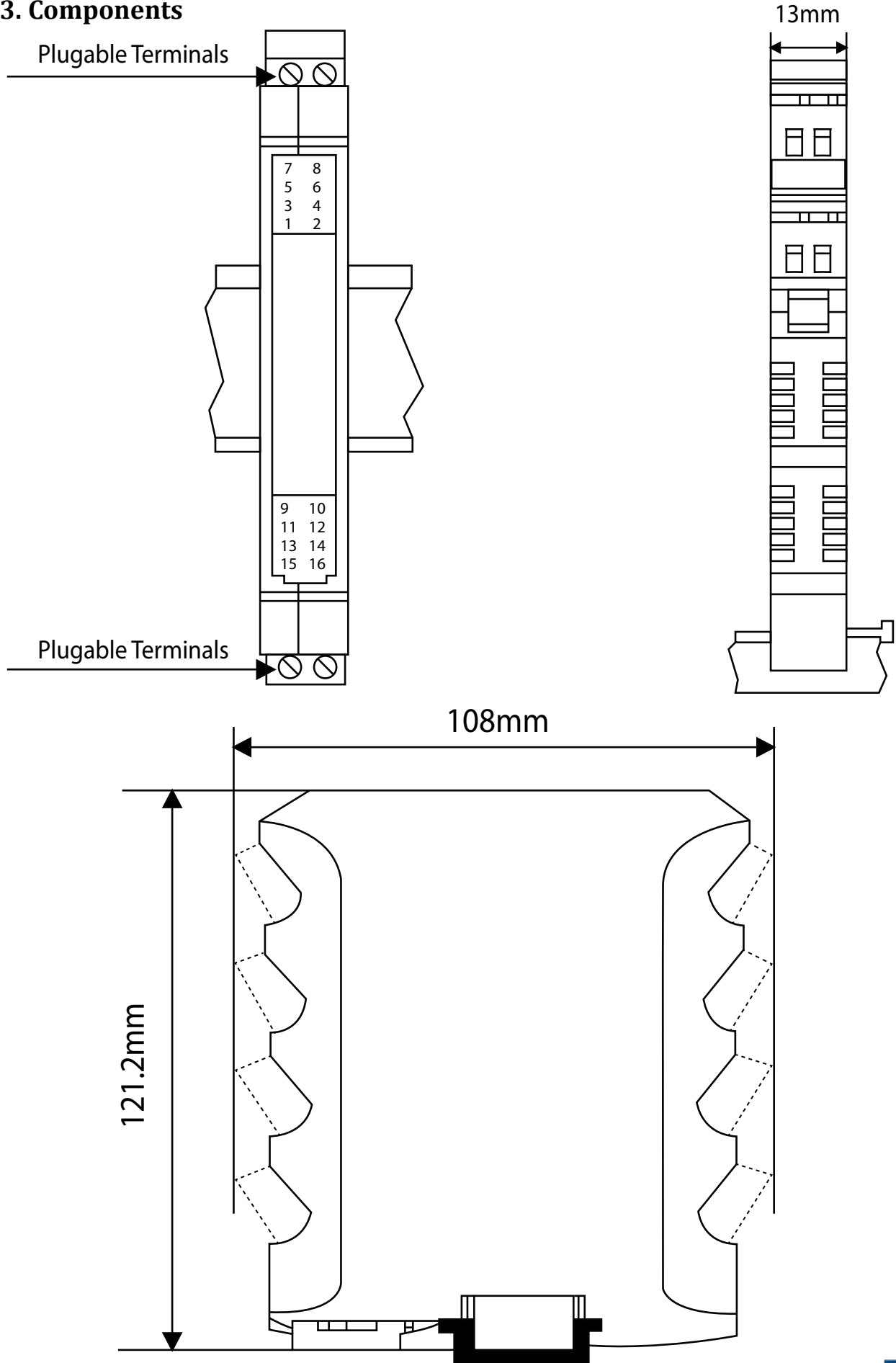

4. Configuration

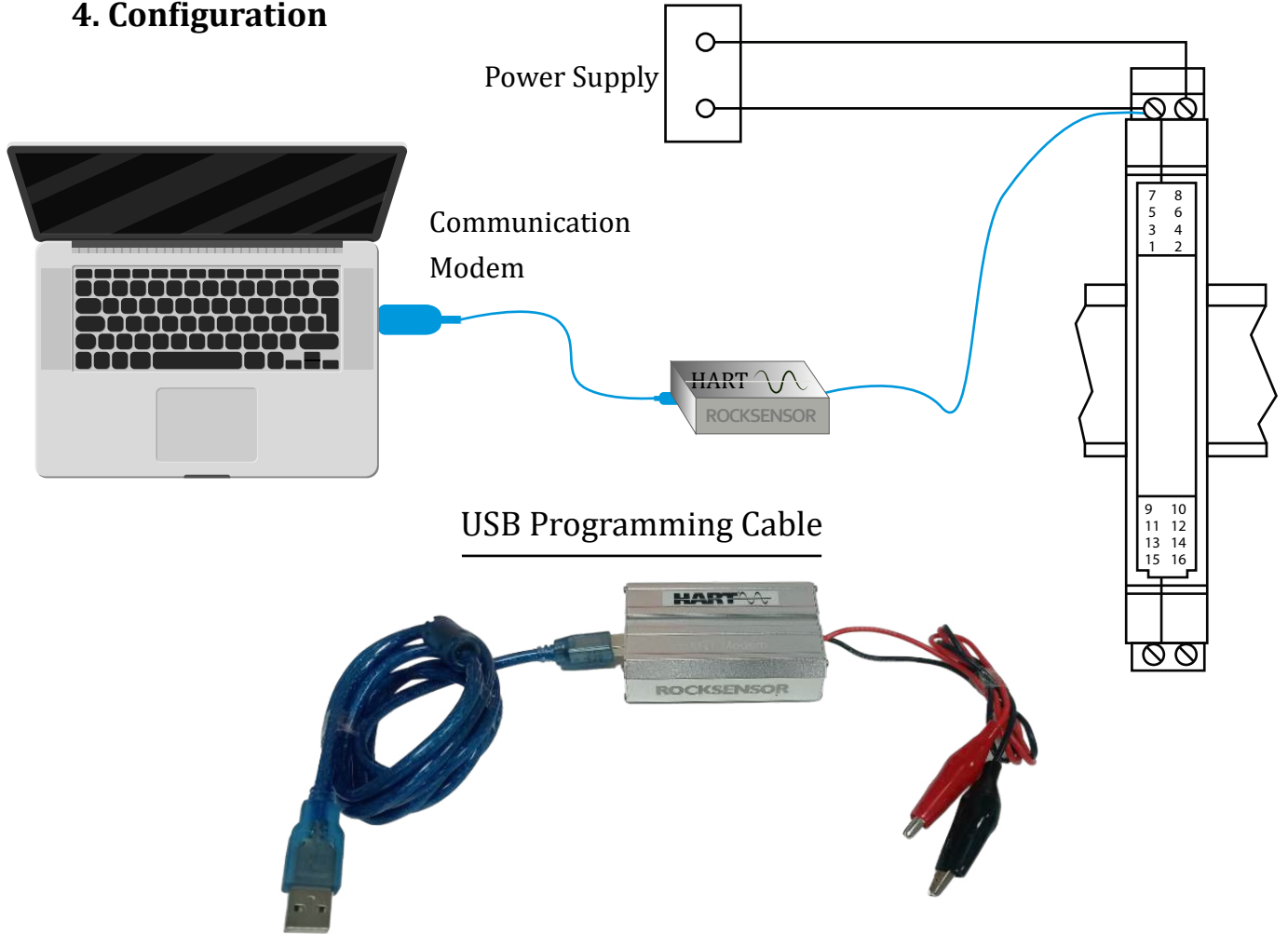

* Please contact Rocksensor team for more details on the software.

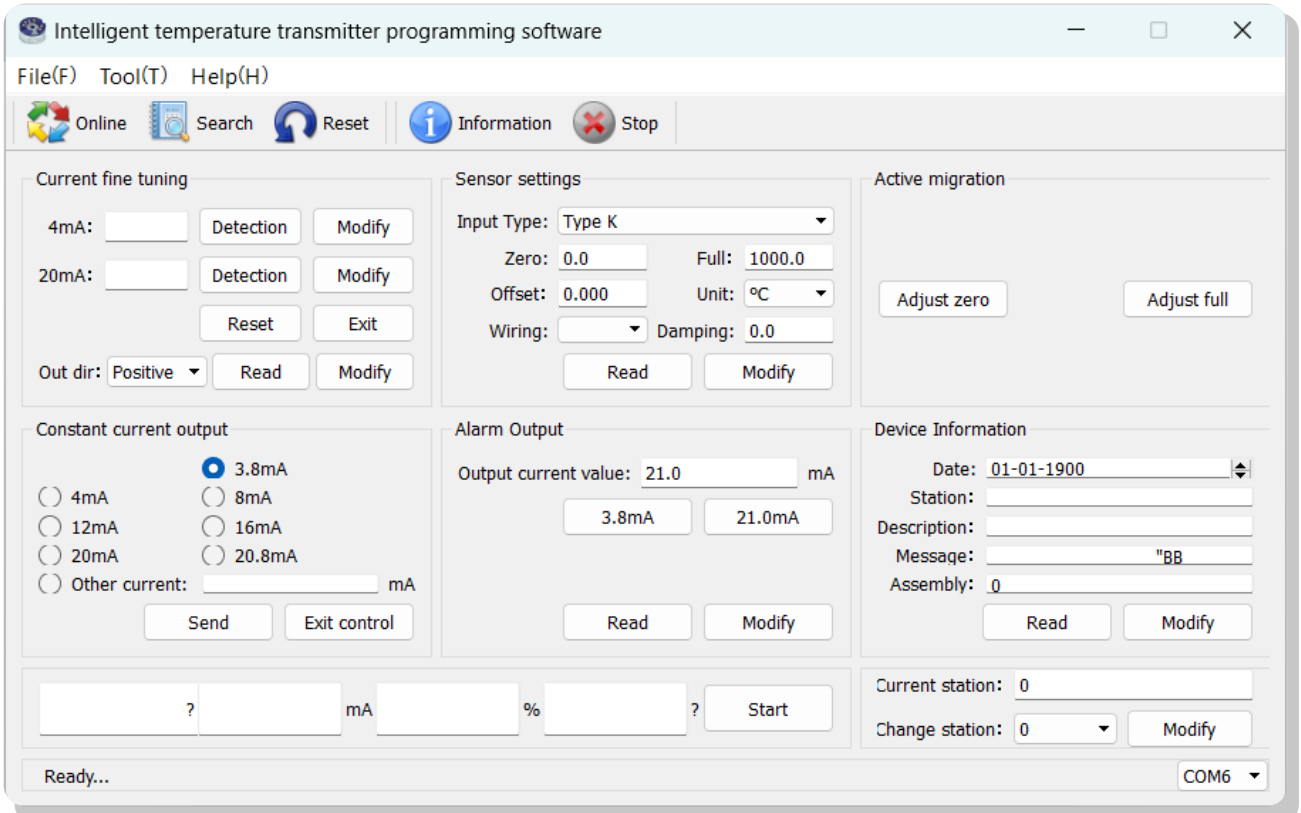

5. Electrical Diagram (with HART)

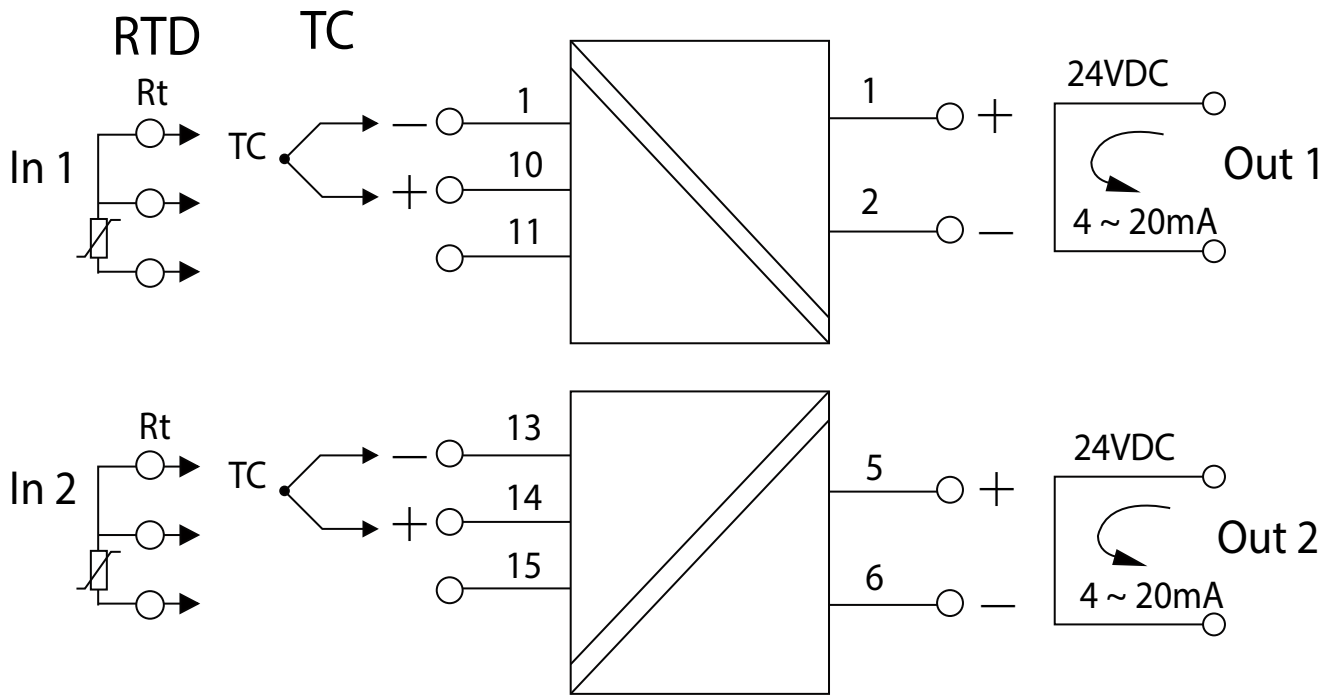

6. Electrical Diagram (without HART)

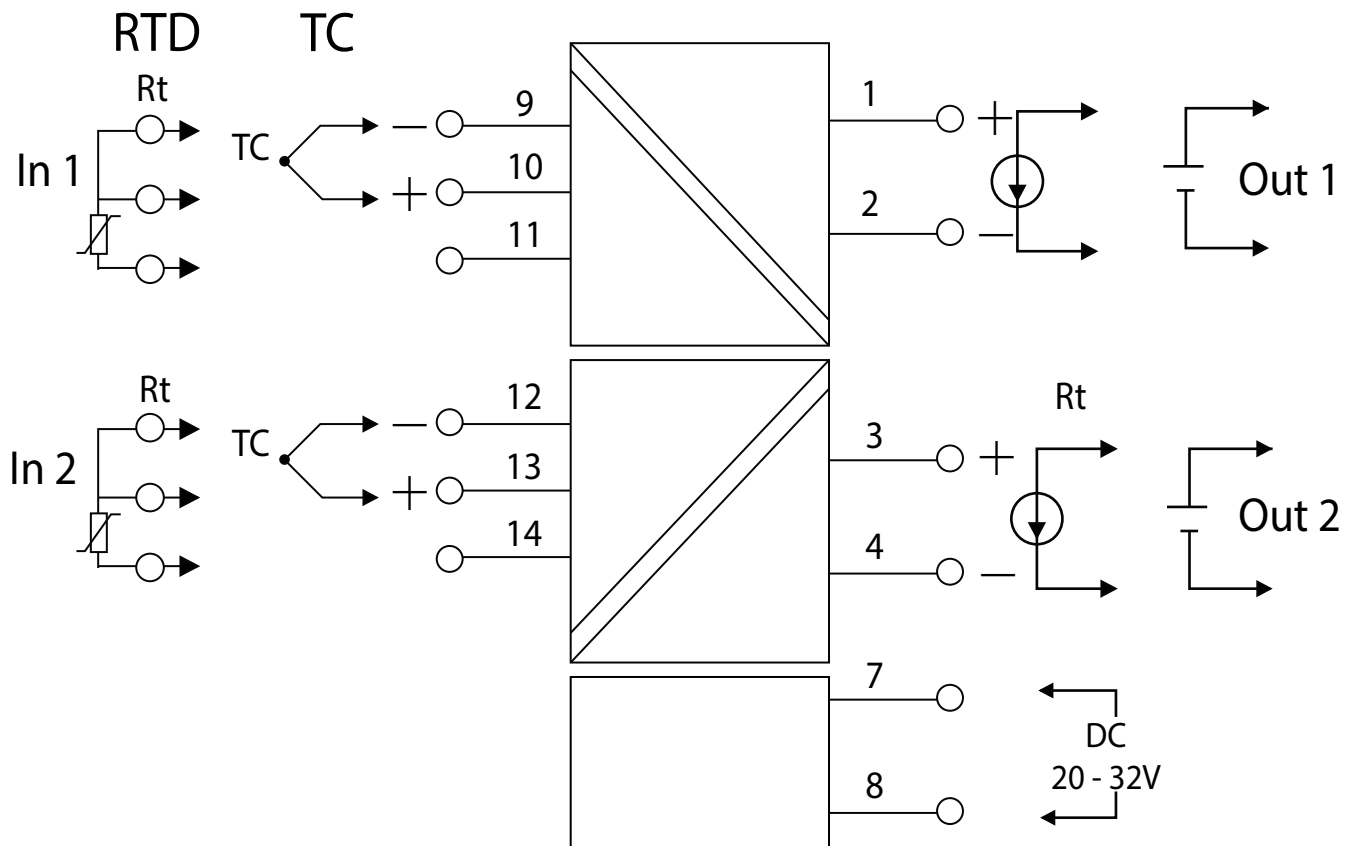

7. Connection with HART

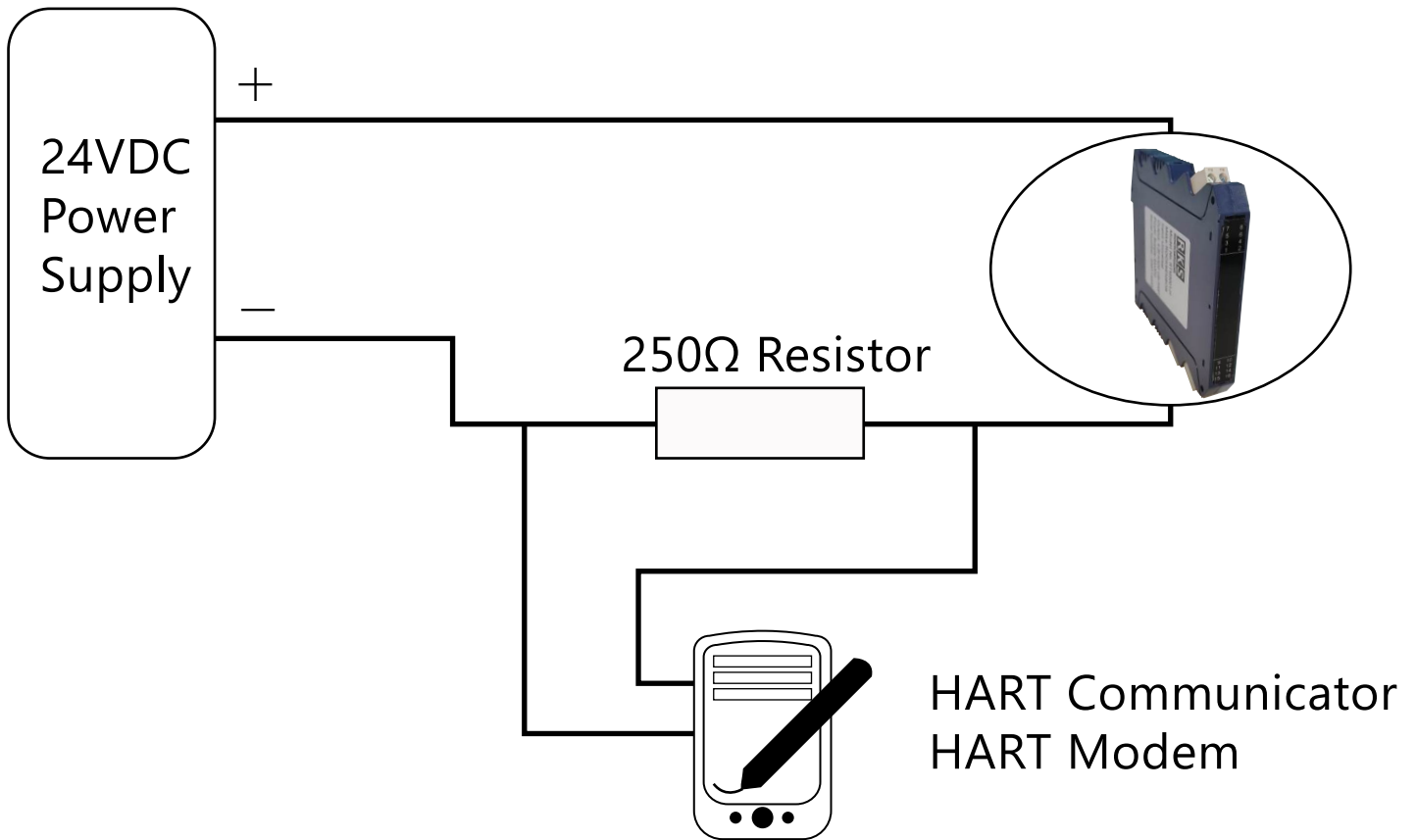

Install temperature transmitters near to the process unit in junction boxes to eliminate the need for thermocouple extension wire and any associated issues.

By connecting two sensors to each Temperature Transmitter and reading them digitally, you can drastically save your expenditures if you have access to HART input cards.

8. Technical Parameters

Parameters	Details
Input type	Thermocouple, RTD
Output Signal	4-20mA and 4-20mA+Hart
Resistor Load (mA output)	$RL \leq (U2-11)/0.021$
Accuracy	$\pm 0.1\%FS$ (HART) / $\pm 0.2\%FS$
Temperature shift	0.0075%FS/°C
Min. Resolution	0.1°C
Cold junction -compensation	- 10 to 50°C
Cold junction-comp. accuracy	$\pm 1^\circ C$
Response time	≤ 1 second
Isolation (HART)	Input-output-power 2KV, 1min, 50Hz
Isolation (Standard)	Input-output-power 1.5KV, 1min, 50Hz
Circuit limit	$\leq 22mA$
Saturation current	Low: 3.8mA, 21mA
Power supply	DC12-40V
Power Consumption	$\leq 1W$ (1 input 1Output);
	$\leq 1.4W$ (2Input2Output)
Electromagnetic compatibility	Compliant with industrial equipment application equipment (IEC 61326-1)
Case material/Class	PC/IP20
Size	121.2 x 108 x 13mm
Working condition	-20 to 60°C; 25% to 85% RH
Storage temperature	-20 to 60°C (No dew)

9. Input type and transmission accuracy:

Input Code	Model	Type (RTD)	Measurement Range	Mini Range	Accuracy
P	RTD	Pt100	-200 ~ 650°C	20°C	±0.1%range or ±0.2°C
C		Cu50	-50 ~ 150°C	20°C	±0.1%range or ±0.2°C
K	Thermocouple	K	-200 ~ 1372°C	50°C	±0.1%range or ±0.5°C
T		T	-200 ~ 400°C	50°C	±0.1%range or ±0.5°C
E		E	-100 ~ 1000°C	50°C	±0.1%range or ±0.5°C
J		J	-100 ~ 1200°C	50°C	±0.1%range or ±0.5°C
N		N	-180 ~ 1300°C	50°C	±0.1%range or ±0.5°C
R		R	-50 ~ 1600°C	500°C	±0.1%range or ±1.5°C
S		S	-50 ~ 1600°C	500°C	±0.1%range or ±1.5°C
B		B	400 ~ 1800°C	500°C	±0.1%range or ±1.5°C

Notes:

1. The above accuracy is based environment temperature : $20 \pm 2^\circ\text{C}$
2. Output accuracy % is according to the set range
3. When thermocouple input measurement, the thermocouple cold junction compensation accuracy is $\leq \pm 1^\circ\text{C}$

10. Ordering Table

RTM5001: DIN Rail Mount Universal Temperature Transmitter						
Order Code: E.g.: RTM5001-1PN1N					Description	
RTM5001	X	-X	-X	X	X	
Input-Output Number	1					1 Input 1 Output
	2					2 Input 2 Output
Input 1	P					Pt100 (default)
	...					Please see below order code list to choose input type
	-X					Customized
Input 2	N					None
	...					Please see below order code list to choose correct code
Output 1				1		4-20mA
				2		4-20mA + Hart
Output 2				N		None
				1		4-20mA + Hart

Example

Model No. RTM5001-1PN2N

DINRail Mount Universal Temperature Transmitter

Input/Output : 1 Input 1 Output

Input 1: Pt100(default)

Input 2: None

Output 1: 4-20mA + HART

Output2: None

Field Instrumentation Range



Pressure Measurement

- Smart Differential Pressure Transmitter
- Smart Gauge Pressure Transmitter
- Smart Absolute Pressure Transmitter
- Miniature Pressure Transducer without display
- Sanitary Gauge/ Absolute Pressure Transmitter

- Submersible Pressure Transmitter
- Remote Seal Differential P.T. with capillary
- Remote Seal Differential P.T. Direct Mount
- Remote Seal Gauge/Absolute P.T. with capillary
- Remote Seal Gauge/Absolute P.T. Direct Mount



Flow Measurement

- Coriolis Mass Flowmeter
- Thermal Gas Mass Flowmeter
- Positive Displacement Flowmeter
- Electromagnetic Flowmeter
- Vortex Flowmeter

- Turbine Flowmeter
- Variable Area Flowmeter
- Clamp On Ultrasonic Flowmeter
- Inline Ultrasonic Flowmeter
- Portable Ultrasonic Flowmeter



Level Measurement

- RADAR Level Transmitter Horn Antenna
- Compact RADAR Level Transmitter
- RADAR Level Transmitter Sanitary
- RADAR Level Transmitter
- Guided Wave RADAR Level Transmitter
- Guided Wave RADAR Level Transmitter
- RADAR Level Transmitter Lens Antenna

- RADAR Level Transmitter Rod Antenna
- Ultrasonic Level Transmitter
- Microwave Barrier Level Switch
- Admittance Level Switch Series
- Vibrating Rod Level Switch Series
- Tuning Fork Level Switch Series



Temperature Measurement

- Head Mount Temperature Transmitter
- Temperature Transmitter for Sanitary Applications

- DIN Rail Temperature Transmitter
- Field Mount Temperature Transmitter

Rocksensor India Pvt. Ltd.

📍 B -36, Sector 67, Noida, Uttar Pradesh - 201301

For more details, contact us on:

☎ +91 928 948 8117 | +91 1204121469

✉ info@rocksensor.in

🌐 www.rocksensor.in

Global Offices

Global HQ & R&D Centre:
Rocksensor Sàrl, Switzerland

North America:
Rocksensor Automation LLC, USA

APAC:
Rocksensor Automation Co. Ltd., Shanghai

For more updates, follow us on:

in: Rocksensor India

▶: Rocksensor

f: Rocksensor

📷: Rocksensor

🐦: Rocksensor India