

Remote Seal/Differential Pressure Level Transmitter RP1001



Diaphragm: SS316L, Hastelloy C, Tantalum



Output: 2-wire system, 4~20mADC HART



Enclosure rating: IP67



Power Supply: 24VDC

ROCKSENSOR AT A GLANCE (ABOUT US)

Rocksensor is one of the global leaders specializing in Process Instrumentation, Research and Development and Designing of Industrial Automation Equipment. We provide highly precise pressure sensors and transmitters, flow metres, level transmitters and temperature transmitters with a prime focus to help our clients efficiently, safely and economically run complex industrial processes.

Rocksensor, headquartered in Switzerland, has its footprint in various geographical regions such as the US, Russia, South Korea, Italy, Germany, Singapore, Malaysia, Morocco, China, Taiwan, Australia, UAE, Brazil and India. Our clients come from some of the major industries such as Oil and Gas, Petrochemicals, Pharmaceuticals, FMCG, Automobiles, Water, Cement, Metal & Mining, and mainly from the Power Industry like Nuclear, Thermal, Hydro, and Solar.

Rocksensor deals in a wide range of highly accurate industrial automation instruments ensuring that even the complex industrial processes happen efficiently.

To fulfill the needs of our clients we make sure that our instruments work in even the harsh environmental conditions offering accurate recordings and communication.

We, at Rocksensor, believe in creating bonds that last a lifetime and create a success story for each and every client. Rocksensor aims to achieve a perfect fit in the global market landscape and establish our footprints across the globe.



CONTENTS

1. Introduction	4
2. Suitable Industries	4
3. Salient Feature (DPT)	4
4. Salient Features (Remote Seal)	4
5. Dimensons (DPT)	5
6. Model Selection Table for Differential Pressure Level Transmitter	5
7. Dimensons (Remote Seal)	5
8. Model Selection Table for Remote Seal	5

KEY APPLICATION INDUSTRIES

- Oil and Gas sector
- Cement
- Metal
- Pulp and Paper
- Agriculture
- Textiles
- Chemicals
- Power
- Water
- Pharmaceutical
- Fertilizer
- Plastics and HVAC

1. Introduction

The Remote Seal/ Differential Pressure Transmitter is suitable to measure liquid, gas, or steam flow as well as liquid level, density and pressure. Remote Seal Differential Pressure Transmitter is used to prevent the medium in the pipeline from directly entering the pressure sensor component of the differential pressure transmitter. It uses a filling fluid such as silicone oil to transfer pressure.

2. Suitable Industries

- Oil & Gas
- Metal
- Chemical
- Pulp & Paper
- Cement
- Agriculture
- Power
- Pharmaceutical
- Water



Differential Pressure Transmitter

3. Salient Features (DPT)

- High Stability Silicon Sensor
- Reference Accuracy upto 0.06%
- Excellent Performance for Overload
- Packaged Temperature Sensor inside
- Inbuilt Reverse Polarity Protection
- Inbuilt Surge Protection
- IP67 Grade Protection
- Integrated Push-button
- HART
- ATEX, CE, SIL, Certified



Remote Seal Differential Pressure Transmitter

4. Salient Features (Remote Seal DPT)

- Isolating Diaphragm: SS316L, Hastelloy C, Gold Plated on SS316L, Tantalum
- Filling Fluid: Silicone Oil, High Temperature Silicone Oil, Ultra Temp. Silicone Oil, Vegetable Oil
- High Temperature upto 600°C
- Flange Size: DN50, DN80, DN100
- Flange Rating: ANSI; 150psi to 600psi & DIN: PN1.6MPa ~ PN10MPa
- Capillary Length: 0 ~12m/ Customised
- Housing: Aluminum with epoxy resin coat/ stainless steel
- With PVC protective coating capillary
- With Lighting protection

5. Dimensons

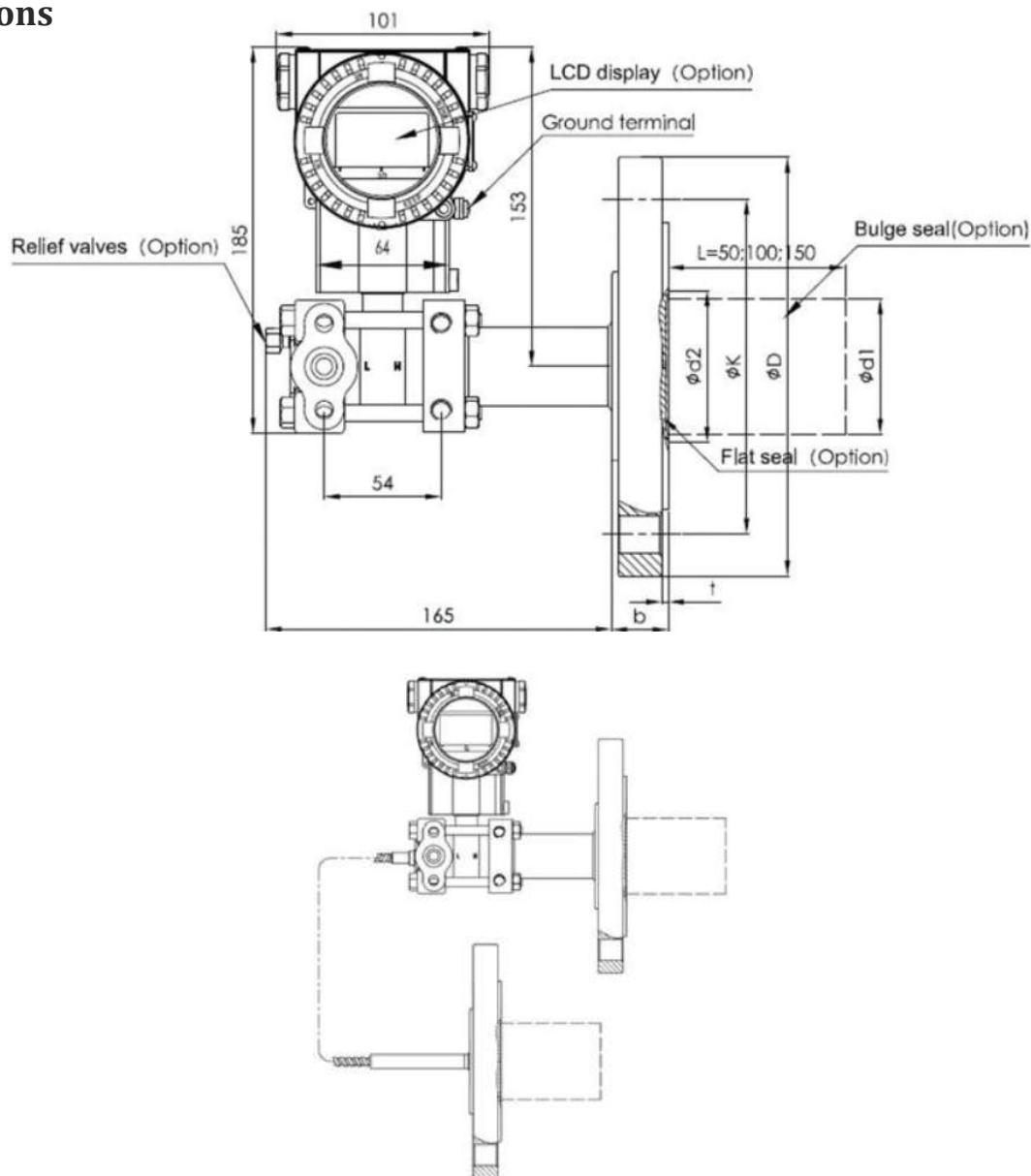

Nominal Diameter	Working Pressure	ϕD	ϕK	$\phi d1$ Plug-in	$\phi d2$ Flat	$\phi d3$	t	b	Required Bolt	
DN 50 (Sealing DIN 2526E) (Flange DIN 2501)	PN 1.6/4MPa	165	125	48.3	57	102	3 ^{+0.5}	20	4	M16
	PN 6.4MPa	180	135	48.3	57	102	3 ^{+0.5}	26	4	M20
	PN 10MPa	195	145	48.3	57	102	3 ^{+0.5}	28	4	M24
DN 80 (Sealing DIN 2526E) (Flange DIN 2501)	PN 1.6/4MPa	200	160	76	75	138	3 ^{+0.5}	24	8	M16
	PN 6.4MPa	215	170	76	75	138	3 ^{+0.5}	28	8	M20
	PN 10MPa	230	180	76	75	138	3 ^{+0.5}	32	8	M24
DN 2" (ANSI B 16.5 RF)	150psi	152.4	120.6	48.3	57	92.1	3 ^{+0.5}	17.4	4	M18
	300psi	165.1	127.0	48.3	57	92.1	3 ^{+0.5}	20.6	8	M18
	600psi	165.1	127.0	48.3	57	92.1	6.35	31.75	8	M18
DN 3" (ANSI B 16.5 RF)	150psi	190.5	152.4	76	75	127	3 ^{+0.5}	22.2	4	M16
	300psi	209.5	168.3	76	75	127	3 ^{+0.5}	27.0	8	M20
	600psi	209.5	168.3	76	75	127	6.35	38.05	8	M20
DN 4" (ANSI B 16.5 RF)	150psi	229	191	89	89	157	3 ^{+0.5}	30	8	M18
	300psi	255	200	89	89	157	3 ^{+0.5}	32	8	M18

Note: The user can choose to install bolts & nuts.

6. Model Selection Table

RP1001	Differential Pressure Transmitter																
Code	1	2	3	4	5	6	7	8	9	10	11	12	...	18			

Accuracy	
±0.06% of span	B
±0.1% of span	C

Sensor Type	
Piezo-resistive Silicone Sensor	1

Output	
4-20mA with HART 7	B

Static Pressure Sensor	
None	0
40 MPa (only applicable to 7MPa rated working pressure, only for span A)	1

Span	
0-100Pa ~ 1kPa (0-10 ~ 100mmH ₂ O / (0-1 ~ 10mbar) (Accuracy 0.1%)	A
0-200Pa ~ 6kPa (0-20 ~ 600mmH ₂ O / (0-2 ~ 60mbar)	B
0-4kPa ~ 40kPa / (0-400 ~ 4000mmH ₂ O) / (0-40 ~ 400mbar)	C
0-2.5kPa~250kPa(0-0.25~25mH ₂ O / (0-25~2500mbar)	D
0-30kPa~3Mpa (0-3~300 mH ₂ O / (0-0.3~30bar)	F

Diaphragm Material	
SS316L Stainless Steel	S
Hastelloy C	H
Gold plated on SS316L	G
FEP plated on SS316L (Silicone Oil)	F
Tantalum (Silicone Oil)	T

Filling Fluid	
Silicone oil	S
Fluorine oil	F

Mounting Bracket	
N	None
1	SS304 Stainless steel
2	Carbon steel galvanized

Special Function	
N	None
F	Square root output
O	Degrease cleansing treatment (Oxygen measurement must be with fluorinated oil filled capsule, Viton (FKM) gasket, <6MPa, <60°C
P	Anti-lightning Function

Gaskets (Sealing Material)	
N	Perbunan (NBR)
F	Viton (FKM)
P	PTFE

Process Connections	
N	7/16-20 UNF and 1/4-18 NPT female thread, No relief valve
B	7/16-20 UNF and 1/4-18 NPT female thread, Relief valves at end of flanges
U	7/16-20 UNF and 1/4-18 NPT female thread, Relief valves at the upper part of the flange side.
D	7/16-20 UNF and 1/4-18 NPT female thread, Relief valve at the lower part of the flange side.
V	Vertical mounting flange, 7/16-20 UNF and 1/4-18 NPT female thread, Relief valves at the upper part of flange side
L	Level
R	Remote Seal

Working Pressure	
0	0.2MPa (only for Span-A)
7	7MPa (only for span-A)
1	16MPa
2	25MPa
3	40MPa

RP1001	Differential Pressure Transmitter							
Code	1	...	13	14	15	16	17	18

Process Connector Accessory	
None	N
Stainless steel oval-shaped flange with 1/2 NPT female thread	1
Stainless steel D-shaped connector with M20x1.5 male thread	2

Integral Indicator	
None	N
LCD Backlit Display	2

Explosion-Proof Option	
None	N
Intrinsic Safety (Exia) - ATEX	I1
Intrinsic Safety (Exia) - IECEx	I2
Isolated Explosion/Flameproof(Exd) - ATEX	D1
Isolated Explosion/Flameproof(Exd) - IECEx	D2
Intrinsically Safe & Flameproof - ATEX	E1
Intrinsically Safe & Flameproof - IECEx	E2

Additional Options	
N	None
A	Exd Cable Entry (Ex-Proof Cable Gland)
E	Hanging Stainless Steel Tag Plate

Enclosure Material	
A1	Die Cast Aluminum
S2	SS316

Electrical Connection	
M	M20*1.5
N	1/2" NPT

6. Model Selection Table for Differential Pressure Level Transmitter

Level Flange Sealing Device Selection						
Code	1	2	3	4	5	6

10	Flange Sealing Device
LT	Level Flange Sealing, No Capillary, +Side

20 Process Connection			
	Nominal Diameter	Sealing Surface Form	Diaphragm/ Sealing Surface Material
A	DN50 DIN2501	E DN2526	SS316L
B	DN50 DIN2501	E DN2526	Hastelloy C
C	DN50 DIN2501	E DN2526	Tantalum(temp±200°C)
H	DN80 DIN2501	E DN2526	SS316L
I	DN80 DIN2501	E DN2526	Hastelloy C
G	DN80 DIN2501	E DN2526	Tantalum(temp±200°C)
R	DN100 DIN2501	E DN2526	SS316L
S	DN100 DIN2501	E DN2526	Hastelloy C
T	DN100 DIN2501	E DN2526	Tantalum(temp±200°C)
D	DN2"ANSI B16.5	RF ANSI B16.5	SS316L
E	DN2"ANSI B16.5	RF ANSI B16.5	Hastelloy C
F	DN2"ANSI B16.5	RF ANSI B16.5	Tantalum(temp±200°C)
K	DN3"ANSI B16.5	RF ANSI B16.5	SS316L
L	DN3"ANSI B16.5	RF ANSI B16.5	Hastelloy C
M	DN3"ANSI B16.5	RF ANSI B16.5	Tantalum(temp±200°C)
N	DN4"ANSI B16.5	RF ANSI B16.5	SS316L
O	DN4"ANSI B16.5	RF ANSI B16.5	Hastelloy C
P	DN4"ANSI B16.5	RF ANSI B16.5	Tantalum(temp±200°C)

30 Working Pressure		
	Working Pressure	Material
1	PN 1MPa/4MPa	DIN 2501
2	PN 6.4MPa	DIN 2501
3	PN 10MPa	DIN 2501
6	Class 150	ANSI B 16.5
7	Class 300	ANSI B 16.5
8	Class 600 ANSI B 16.5	ANSI B 16.5 (excluding DN4" ANSI B 16.5)
4	PN 1MPa/ 1.6MPa (DN100)	DIN 2501
5	PN 2.5MPa/ 4MPa (DN100)	DN2501

40 Filling Fluid		
	Fluid	Temperature Range
S	Silicon Oil	-30° ~ 200°C
V	Vegetable Oil	0° ~ 250°C
F	Fluorine Oil	-30° ~ 260°C

60 Diaphragm Protection (Multiple Choice)	
N	None
22	DN50/2" coated PFA (perfluoroalkylate) (temperature≤260°C)
23	DN80/3" coated PFA (perfluoroalkylate) (temperature≤260°C)
24	DN100/4" coated PFA (perfluoroalkylate) (temperature≤260°C)
32	DN50/2" posted diaphragm PTFE film (polytetrafluoroethylene film) (temperature≤200°C)
33	DN80/3" posted diaphragm PTFE film (polytetrafluoroethylene film) (temperature≤200°C)
34	DN100/4" posted diaphragm PTFE film (polytetrafluoroethylene film) (temperature≤200°C)
42	DN50/2" SS316L coated with FEP (fluorinated ethylene propylene copolymer) (temperature≤180°C)(only for plug-in type)
43	DN80/3" SS316L coated with FEP (fluorinated ethylene propylene copolymer) (temperature≤180°C)(only for plug-in type)
44	DN100/4" SS316L coated with FEP (fluorinated ethylene propylene copolymer) (temperature≤180°C)(only for plug-in type)
52	DN50/2" SS316L coated with PFA (perfluoroalkylate) (temperature≤260°C) (only for plug-in)
53	DN80/3" SS316L coated with PFA (perfluoroalkylate) (temperature≤260°C) (only for plug-in)
54	DN100/4" SS316L coated with PFA (perfluoroalkylate) (temperature≤260°C) (only for plug-in)
6	Vacuum Treatment (temperature-120degC, working pressure-50KPa abs)
72	Gold plating on DN50/2"SS316L
73	Gold plating on DN80/3"SS316L
74	Gold plating on DN100/4"SS316L
8	Degrease Cleaning Treatment

50 Process Connections	
F	Flat
H	Bulge sealing, SS316L, extended diaphragm seal 50mm
I	Bulge sealing, SS316L, extended diaphragm seal 100mm
G	Bulge sealing, SS316L, extended diaphragm seal 150mm
L	Bulge sealing, Hastelloy C, extended diaphragm seal 50mm
M	Bulge sealing, Hastelloy C, extended diaphragm seal 100mm
N	Bulge sealing, Hastelloy C, extended diaphragm seal 150mm

Example: RP1001-C1B0CSS1LNNNN2NNa1N+LT-D6FSN

C : Reference Accuracy $\pm 0.1\%$ of span

1 : Piezoresistive Silicon Sensor

B : 4 - 20 mADC HART 7 Output

0 : Static Pressure Sensor None

C : Span : 0-4kPa ~ 40kPa / (0-400 ~ 4000mmH2O) / (0-40 ~ 400mbar)

S : SS316L stainless steel

S : Filling Fluid Silicon Oil

1 : Working Pressure 16 MPa

L : Process Connections : DN2" flange on HP side & 1/4"NPT(F) on LP side

N : Gasket Perbunan (NBR)

N : Special Function : None

N : Mounting Bracket : None

N : Process Connector Accessory : None

2 : Backlit LCD Display

N : Explosion-Proof Option : None

N : 1/2"NPT(F) Electrical Connection

A1 : Die Cast Aluminium Housing

A : Additional Options : None

LT- Level flange on HP side

D : DN 2" flange, Diaphragm Material SS316L

6 : Flange Class 150 RF ANSI B16.5

F : Flat Sealing

S : Filling Fluid Silicon Oil -30~200degC

N : Diaphragm Protection None

Other details are as per the attached catalogue

7. Dimensions (Remote Seal DPT)

Figure1:

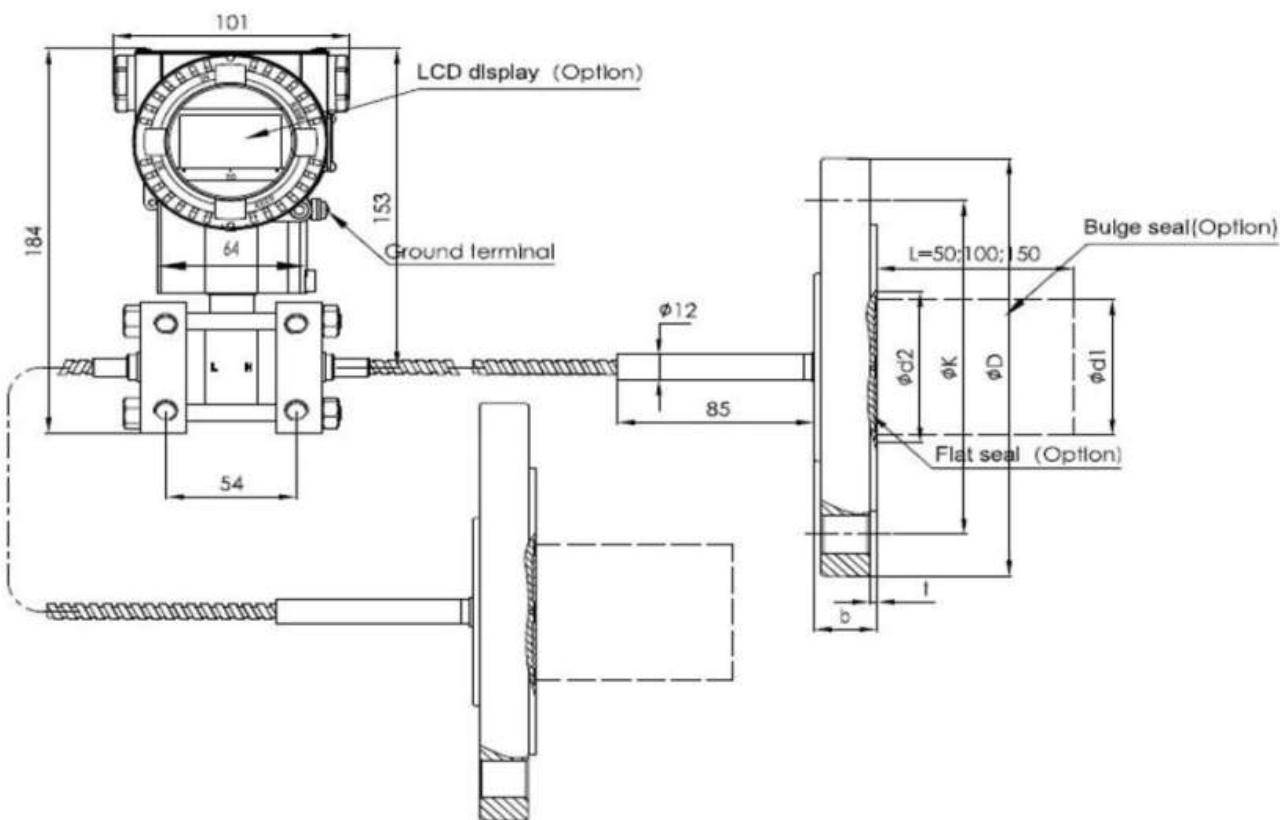
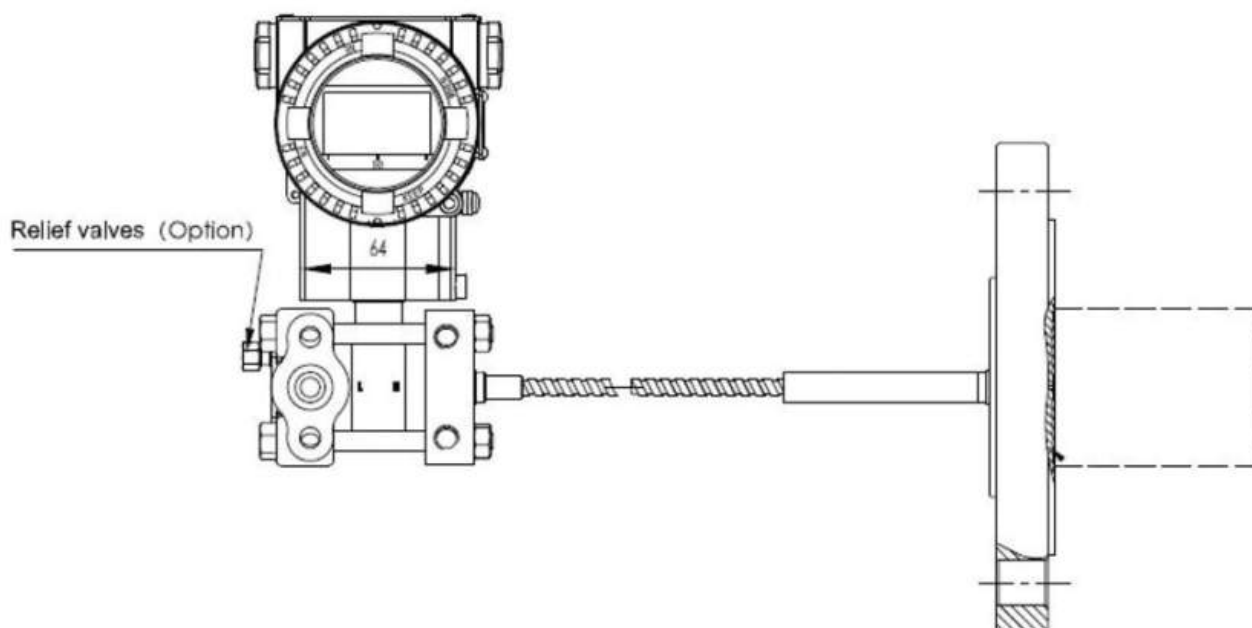

Figure2: Basic type single side differential pressure remote transmission sealing device



NOTE: (1) The single-sided basic differential pressure remote transmission sealing device can be installed on the high or low pressure side of the transmitter.

(2) The transmitter body of the single-sided differential pressure remote transmission sealing device is installed in the way as the RP1001 series differential pressure transmitter.

7. Dimensions (Remote Seal DPT)

Nominal Diameter	Working Pressure	φ D	φ K	φ d1 Plug-in	φ d2 Flat	φ d3	t	b	Required Bolt	
									Quantity	Thread
DN 50 (Sealing DIN 2526E) (Flange DIN 2501)	PN 1.6/4MPa	165	125	48.3	57	102	3 ^{+0.5}	20	4	M16
	PN 6.4MPa	180	135	48.3	57	102	3 ^{+0.5}	26	4	M20
	PN 10MPa	195	145	48.3	57	102	3 ^{+0.5}	28	4	M24
DN 80 (Sealing DIN 2526E) (Flange DIN 2501)	PN 1.6/4MPa	200	160	76	75	138	3 ^{+0.5}	24	8	M16
	PN 6.4MPa	215	170	76	75	138	3 ^{+0.5}	28	8	M20
	PN 10MPa	230	180	76	75	138	3 ^{+0.5}	32	8	M24
DN 100 (Sealing DIN 2526E) (Flange DIN 2501)	PN 1/6MPa	220	180	89	110	158	3 ^{+0.5}	22	8	M16
	PN 2.5/4MPa	235	190	89	110	162	3 ^{+0.5}	26	8	M20
DN 2" (ANSI B 16.5 RF)	150psi	152.4	120.6	48.3	57	92.1	3 ^{+0.5}	17.4	4	M16
	300psi	165.1	127.0	48.3	57	92.1	3 ^{+0.5}	20.6	8	M16
	600psi	165.1	127.0	48.3	57	92.1	6.35	31.75	8	M16
DN 3" (ANSI B 16.5 RF)	150psi	190.5	152.4	76	75	127	3 ^{+0.5}	22.2	4	M16
	300psi	209.5	168.3	76	75	127	3 ^{+0.5}	27.0	8	M20
	600psi	209.5	168.3	76	75	127	6.35	38.05	8	M20
DN 4" (ANSI B 16.5 RF)	150psi	229	191	89	89	157	3 ^{+0.5}	30	8	M16
	300psi	255	200	89	89	157	3 ^{+0.5}	32	8	M20

Note: The user can choose to install bolts & nuts.

Figure3: Two flange remote seal of threaded mount device.

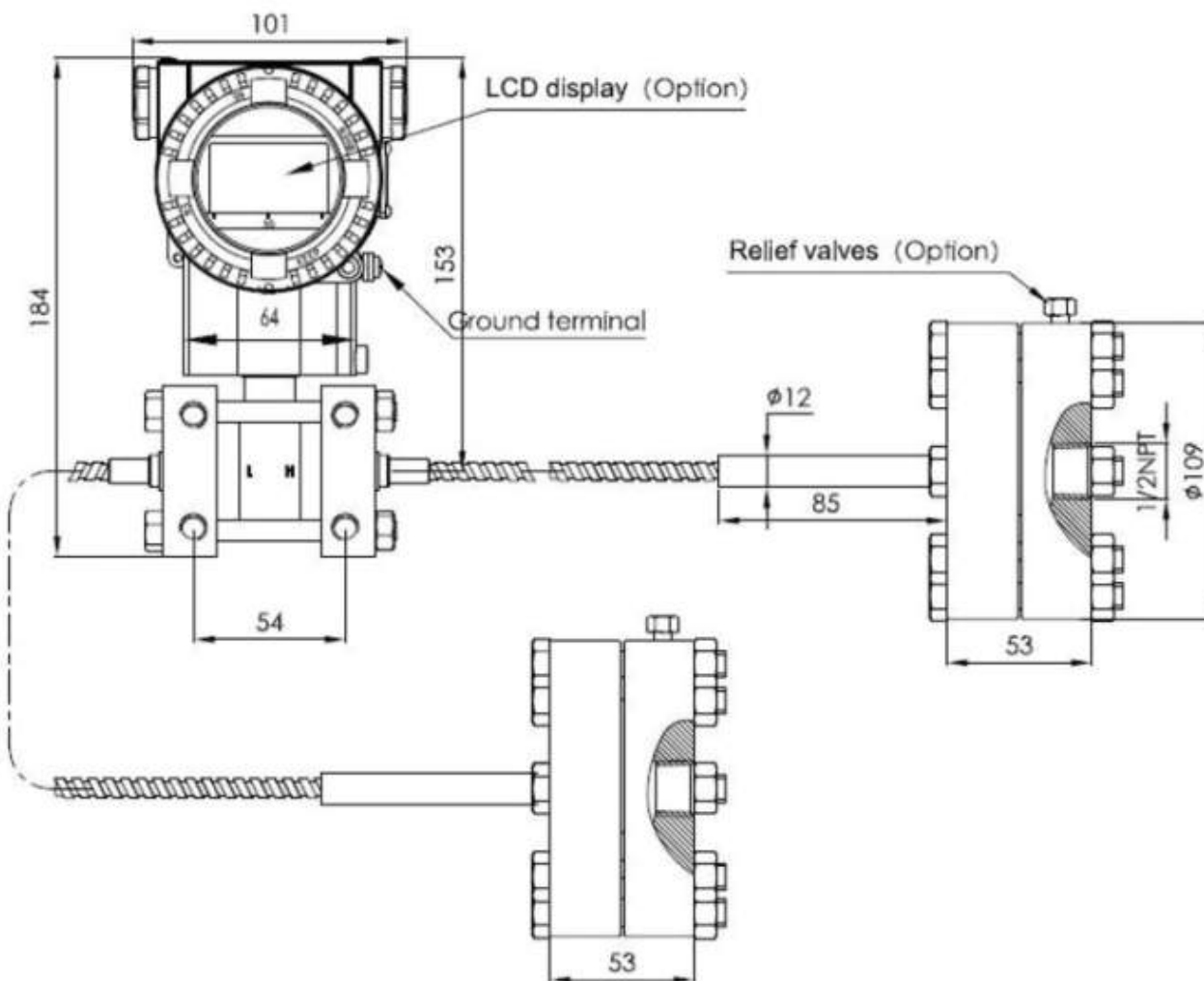

7. Dimensions (Remote Seal DPT)

Figure4: Single-sided threaded type differential pressure remote transmission sealing device

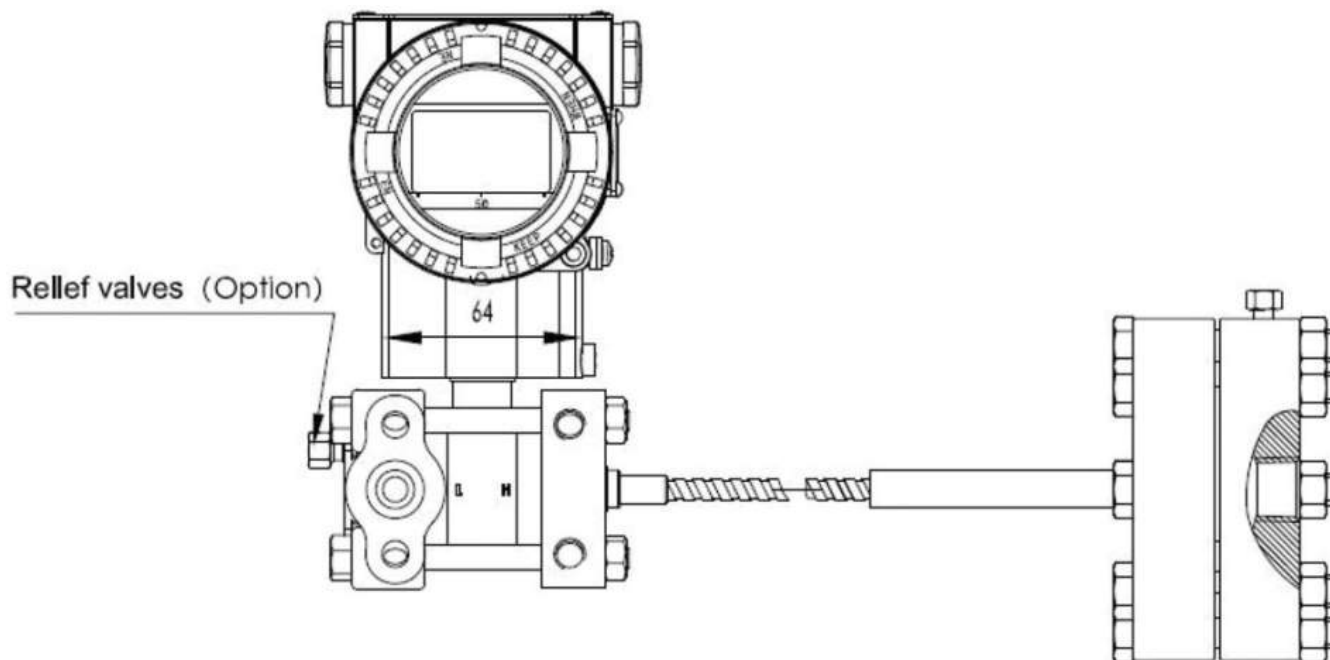

NOTE: (1) The single-sided thread-mounted differential pressure remote transmission sealing device can be installed on the high-voltage side of the transmitter body or on the low-voltage side of the transmitter.

(2) The transmitter body of the single-sided or double-sided thread-mounted differential pressure remote transmission sealing device is installed in the same manner as the RP1001 series differential pressure transmitter.

Remote Seal/ DP Level Transmitter RP1001

DRD Flange Option Dimension in mm

Model RP1001 with DRD connection and retainer Flange
Assembly alternatively by direct welding or via capillary

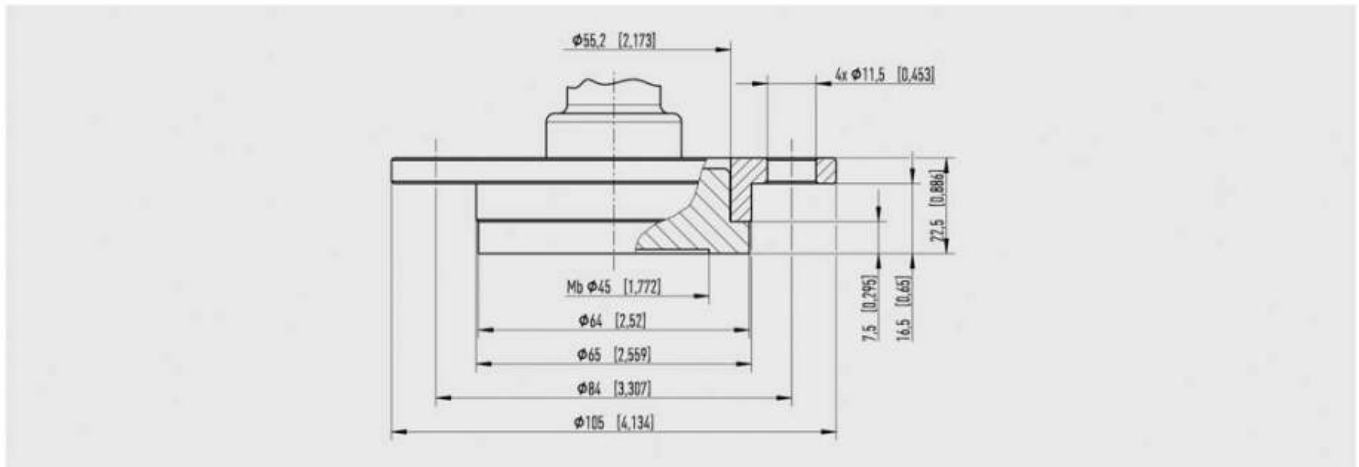

Welding flange for DRD connection (option)

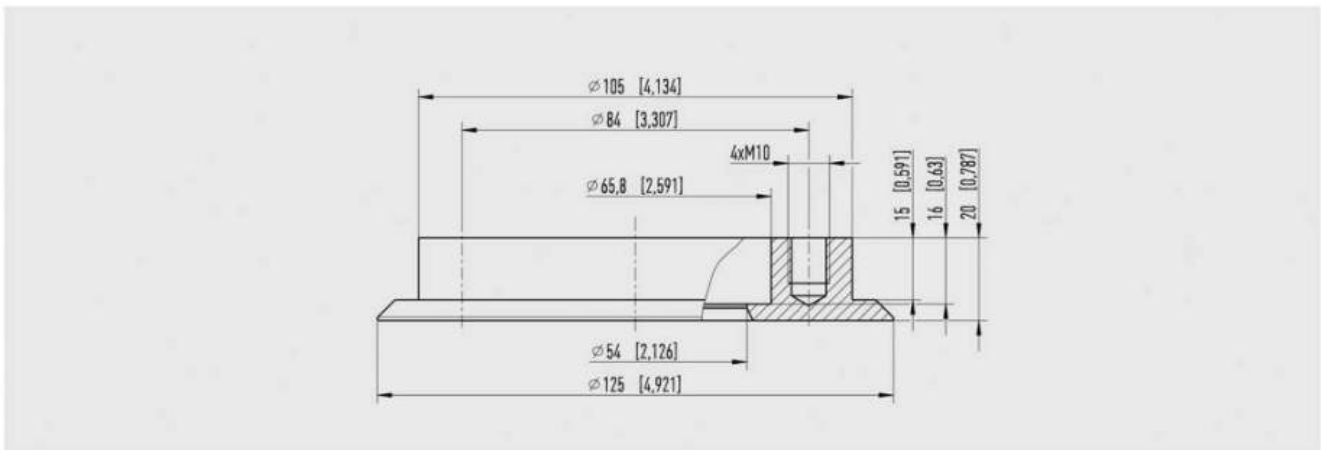

Diaphragm Seal with sterile connection, Model RP1001

8. Model Selection Table for Remote Seal DPT

RP1001	Remote Seal DPT							
Code	1	2	3	4	5	6	7	8

Flange Sealing Device	
RH	With capillary + side
RL	With capillary - side

Process Connection			
	Nominal Diameter	Sealing Surface	Diaphragm Material
A	DN50 DIN2501	E DN2526	SS316L
B	DN50 DIN2501	E DN2526	Hastelloy C
C	DN50 DIN2501	E DN2526	Tantalum(temp±200°C)
H	DN80 DIN2501	E DN2526	SS316L
I	DN80 DIN2501	E DN2526	Hastelloy C
G	DN80 DIN2501	E DN2526	Tantalum(temp±200°C)
R	DN100 DIN2501	E DN2526	SS316L
S	DN100 DIN2501	E DN2526	Hastelloy C
T	DN100 DIN2501	E DN2526	Tantalum(temp±200°C)
D	DN2"ANSI B16.5	RF ANSI B16.5	SS316L
E	DN2"ANSI B16.5	RF ANSI B16.5	Hastelloy C
F	DN2"ANSI B16.5	RF ANSI B16.5	Tantalum(temp±200°C)
K	DN3"ANSI B16.5	RF ANSI B16.5	SS316L
L	DN3"ANSI B16.5	RF ANSI B16.5	Hastelloy C
M	DN3"ANSI B16.5	RF ANSI B16.5	Tantalum(temp±200°C)
N	DN4"ANSI B16.5	RF ANSI B16.5	SS316L
O	DN4"ANSI B16.5	RF ANSI B16.5	Hastelloy C
P	DN4"ANSI B16.5	RF ANSI B16.5	Tantalum(temp±200°C)

Working Pressure		
1	PN 1MPa/4MPa	DIN 2501
2	PN 6.4MPa	DIN 2501
3	PN 10MPa	DIN 2501
6	Class 150	ANSI B 16.5
7	Class 300	ANSI B 16.5
8	Class 600 ANSI B 16.5	(excluding DN4" ANSI B16.5)
4	PN 1MPa/ 1.6MPa DN100)	DIN 2501
5	PN 2.5MPa/ 4MPa (DN100)	DIN 2501

Connection Type	
F	Flat
H	Bulge sealing SS316L , extended diaphragm seal 50mm
I	Bulge sealing, SS316L, extended diaphragm seal 100mm
G	Bulge sealing, SS316L, extended diaphragm seal 150mm
L	Bulge sealing, Hastelloy C, extended diaphragm seal 50mm
M	Bulge sealing, Hastelloy C, extended diaphragm seal 100mm
N	Bulge sealing, Hastelloy C, extended diaphragm seal 150mm

Diaphragm Protection (Multiple Choice)	
N	None
22	DN50/2" coated PFA (perfluoroalkylate) (temperature≤260°C)
23	DN80/3" coated PFA (perfluoroalkylate) (temperature≤260°C)
24	DN100/4" coated PFA (perfluoroalkylate) (temperature≤260°C)
32	DN50/2" posted diaphragm PTFE film (polytetrafluoroethylene film) (temperature≤200°C)
33	DN80/3" posted diaphragm PTFE film (polytetrafluoroethylene film) (temperature≤200°C)
34	DN100/4" posted diaphragm PTFE film (polytetrafluoroethylene film) (temperature≤200°C)
52	DN50/2"SS316L coated with PFA (perfluoroalkylate) (temperature≤260°C) (only for plug-in)
53	DN80/3"SS316L coated with PFA (perfluoroalkylate) (temperature≤260°C) (only for plug-in)
54	DN100/4"SS316L coated with PFA (perfluoroalkylate) (temperature≤260°C) (only for plug-in)
6	Vacuum Treatment (temperature-120degC, working pressure-50KPa abs)
72	Gold plating on DN50/2"SS316L
73	Gold plating on DN80/3"SS316L
74	Gold plating on DN100/4"SS316L
8	Degrease Cleaning Treatment

Capillary Component Characteristics	
N	None
P	With PVC protective coating capillary

Capillary Length	
01	1m
02	2m
03	3m
04	4m
05	5m
06	6m
07	7m
08	8m
09	9m
10	10m
11	11m
12	12m
....	...

Filling Fluid		
S	Silicon Oil	-30° ~ 200°C
H	High Temp. Silicon Oil	-10° ~ 350°C
V	Vegetable Oil	0° ~ 250°C
F	Fluorine Oil	-30° ~ 260°C
L	Ultra-low temp. filling solution	-100~100°C (not applicable to RN type)
Z	Ultra High temp. filling solution	-10~600°C (not applicable to RN type)

Example: RP1001-C1B0CSS1RNN2N2NNA1N+RH-D6FS02NN+RL-D6FS02NN

C : Reference Accuracy $\pm 0.1\%$ of span

1 : Piezoresistive Silicon Sensor

B : 4 - 20 mADC HART 7 Output

0 : Static Pressure Sensor None

C : Span : 0-400Pa~40KPa (0-40 ~ 4000mmH2O/{0-20 ~ 400mbar})

S : SS316L stainless steel

S : Filling Fluid Silicon Oil

1 : Working Pressure 16 MPa

R : Process Connections : DN2" flange on HP & LP side

N : Gasket Perbunan (NBR)

N : Special Function : None

2 : Mounting Bracket : Carbon steel galvanized

N : Process Connector Accessory : None

2 : Backlit LCD Display

N : Explosion-Proof Option : None

N : 1/2"NPT(F) Electrical Connection

A1 : Die Cast Aluminium Housing

N : None

RH/ RL : Flange Sealing at HP & LP side

D : DN 2" flange, Diaphragm Material SS316L

6 : Flange Class 150 RF ANSI B16.5

F : Flat Sealing

S : Filling Fluid Silicon Oil (-30° ~ 200°C)

02 : Capillary Length 2m

N : None

N : None

Field Instrumentation Range



Pressure Measurement

- Smart Differential Pressure Transmitter
- Smart Gauge Pressure Transmitter
- Smart Absolute Pressure Transmitter
- Miniature Pressure Transducer without display
- Sanitary Gauge/ Absolute Pressure Transmitter
- Submersible Pressure Transmitter
- Remote Seal Differential P.T. with capillary
- Remote Seal Differential P.T. Direct Mount
- Remote Seal Gauge/Absolute P.T. with capillary
- Remote Seal Gauge/Absolute P.T. Direct Mount



Flow Measurement

- Coriolis Mass Flowmeter
- Thermal Gas Mass Flowmeter
- Positive Displacement Flowmeter
- Electromagnetic Flowmeter
- Vortex Flowmeter
- Turbine Flowmeter
- Variable Area Flowmeter
- Clamp On Ultrasonic Flowmeter
- Inline Ultrasonic Flowmeter
- Portable Ultrasonic Flowmeter



Level Measurement

- RADAR Level Transmitter Horn Antenna
- Compact RADAR Level Transmitter
- RADAR Level Transmitter Sanitary
- RADAR Level Transmitter
- Guided Wave RADAR Level Transmitter
- Guided Wave RADAR Level Transmitter
- RADAR Level Transmitter Lens Antenna
- RADAR Level Transmitter Rod Antenna
- Ultrasonic Level Transmitter
- Microwave Barrier Level Switch
- Admittance Level Switch Series
- Vibrating Rod Level Switch Series
- Tuning Fork Level Switch Series



Temperature Measurement

- Head Mount Temperature Transmitter
- Temperature Transmitter for Sanitary Applications
- DIN Rail Temperature Transmitter
- Field Mount Temperature Transmitter

Rocksensor India Pvt. Ltd.

📍 B -36, Sector 67, Noida, Uttar Pradesh - 201301

For more details, contact us on:

☎ +91 928 948 8117 | +91 1204121469

✉ info@rocksensor.in

🌐 www.rocksensor.in

Global Offices

Global HQ & R&D Centre:
Rocksensor Sàrl, Switzerland

North America:
Rocksensor Automation LLC, USA

APAC:
Rocksensor Automation Co. Ltd., Shanghai

For more updates, follow us on:

in: Rocksensor India

▶: Rocksensor

f: Rocksensor

📷: Rocksensor

🐦: Rocksensor India