

Vortex Flowmeter

RF3400



Accuracy: $\pm 1\%$, $\pm 1.5\%$



Temperature: 40 ~ +350°C



Communication: RS485 MODBUS or HART



Body Material: SS304, SS316 (Optional)

**Product
Datasheet**

ROCKSENSOR AT A GLANCE (ABOUT US)

Rocksensor is one of the global leaders specializing in Process Instrumentation, Research and Development and Designing of Industrial Automation Equipment. We provide highly precise pressure sensors and transmitters, flow metres, level transmitters and temperature transmitters with a prime focus to help our clients efficiently, safely and economically run complex industrial processes.

Rocksensor, headquartered in Switzerland, has its footprint in various geographical regions such as the US, Russia, South Korea, Italy, Germany, Singapore, Malaysia, Morocco, China, Taiwan, Australia, UAE, Brazil and India. Our clients come from some of the major industries such as Oil and Gas, Petrochemicals, Pharmaceuticals, FMCG, Automobiles, Water, Cement, Metal & Mining, and mainly from the Power Industry like Nuclear, Thermal, Hydro, and Solar.

Rocksensor deals in a wide range of highly accurate industrial automation instruments ensuring that even the complex industrial processes happen efficiently.

To fulfill the needs of our clients we make sure that our instruments work in even the harsh environmental conditions offering accurate recordings and communication.

We, at Rocksensor, believe in creating bonds that last a lifetime and create a success story for each and every client. Rocksensor aims to achieve a perfect fit in the global market landscape and establish our footprints across the globe.



CONTENTS

1. Introduction	3
2. Principle	3
3. Application	3
4. Feature	4
5. Structure	4-5
6. Technical Data	6
7. Flow Range	7-10
8. Dimension	11-13
9. Vortex Flowmeter Installation	14
10. Model Selection Table	15

KEY APPLICATION INDUSTRIES

- Oil and Gas sector
- Cement
- Metal
- Pulp and Paper
- Agriculture
- Textiles
- Chemicals
- Power
- Water
- Pharmaceutical
- Fertilizer
- Plastics and HVAC

1. Introduction

Vortex Flowmeter works on the Karman vortex street principle that swirls generated by a bluff body in the pipe. The number of swirls are proportional to the volumetric flow in the pipe. Vortex flowmeter widely used for gases, steam and liquid applications. It is ideal for measuring saturated and superheated steam in large facilities to improve steam production efficiency.

2. Principle

When the fluid in the pipeline passes the bluff body (triangular prism), vortices will be generated due to the acceleration of partial flow rate. The vortices will arise alternatively in two lines, which is called Karman vortex.

The releasing frequency of Karman vortex depends on the size of triangle prism and flow rate of fluid, while independent of the medium feature parameter, such as the temperature, pressure, it can be indicated by the following formulas:

$$F = sR \times v (1-1.27 \times d/D)$$

$$Q = 3600 \times F/K$$

$$M = Q \times P$$

F = The releasing frequency of Karman vortex (Hz)

Sr = Strouhal number (unit: dimensions)

V = Medium flow rate (m/s)

d = The width of triangle prism

D = Vortex meter inner diameter (m)

Q = Instantaneous volume flow rate (m³/h)

K = Vortex meter coefficient (unit pulse number/m³)

M = Instantaneous quality flow rate (kg/h)

P = Fluid density (kg/m³)

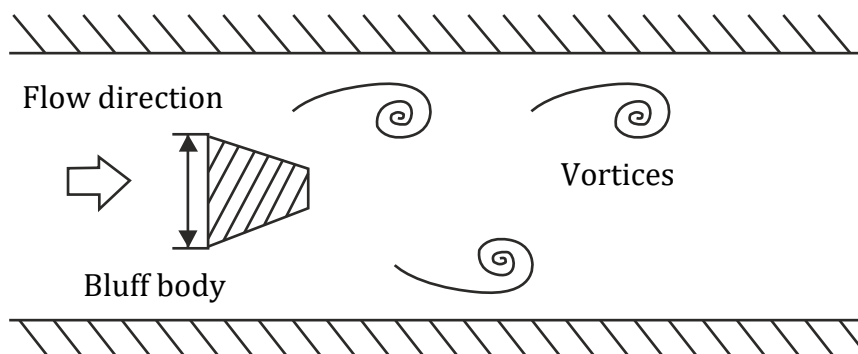

3. Application

Applications in the chemicals and petrochemicals industries, for example in the power generation and heat-supply systems involve widely differing fluids:

- Saturated steam
- Superheated steam
- Compressed air
- Nitrogen
- Liquefied gases
- Flue gases
- Carbon dioxide
- Fully demineralized water
- Solvents
- Heat-transfer oils
- Boiler feedwater
- Condensate, etc.

4. Features



- Integrated pressure and temperature compensation
- 4-20mA, pulse with HART or pulse with RS485 are selectable
- Wide temperature range up to highest temperature 350°C
- Embedded sensor, 4 piezo-electric crystal encapsulated inside the sensor.
- No moving parts, no abrasion, non-wearing parts inside, fully welded SS304 body (SS316 selectable)

5. Structure

• Connection Type

		
<p>Flange Connection</p>	<p>Wafer Connection</p>	<p>Tri-clamp Connection</p>
		
<p>Insertion Type</p>	<p>Thread Connection</p>	

• Compact Type and Remote Type

		
<p>Compact Type</p>	<p>Remote converter type (standard cable 10m, max cable 20m)</p>	

• Remote Type with Flow Computer

		
<p>Flow computer type (standard cable 10m, longer cable can be customized)</p>		

6. Technical data

Parameters	Details	
Measured Medium	Liquid, Gas, Steam	
Medium Temp.	(-)40 ~ +250°C; (-)40 ~ +350°C (high temperature type)	
Pressure	Flange	DIN PN10/PN16/PN25/PN40 20K/30K/40K ANSI 150#/300#
	Wafer	4.0MPa
	Thread	1.6MPa
	Tri-clamp	1.6MPa
	Insertion	1.6MPa
Accuracy	±1.0% (Flange/Wafer/Thread/Tri-clamp) ±1.5% (Insertion type)	
Flow Range	Liquid:0.4-7.0m/s; Gas:4.0-60.0m/s; Steam:5.0-70.0m/s	
Specifications	DN15-DN300 (flange/wafer type) DN80-DN2000 (insertion type) DN15-DN100 (thread/sanitary type)	
Body Material	SS304 (standard) SS316 (optional)	
Reynolds Number	Normal $2 \times 10^4 \sim 7 \times 10^6$	
Resistance Coefficient	$C_d \leq 2.6$	
Vibration Acceleration Allowed	$\leq 0.2g$	
Protection Grade	IIG Exia IICT5 Ga	
Measuring range	Ambient Temp.	(-)40°C ~ 65°C (Non ex-proof site) 20°C ~ 55°C (Ex-proof site)
	Relative Humidity	$\leq 85\%$
	Pressure	86-106kPa
Power Supply	DC12-30V or 3.6V lithium battery powered	
Signal Output	4-20mA, Pulse	
Communication	RS485 Modbus or HART	

7. Flow Range

• **Table 1 Liquid and Air Flow Range Table (m³/h)**

Nominal DN(mm)	Liquid (m ³ /h)		Air (m ³ /h)	
	Standard Range	Extended Range	Standard Range	Extended Range
15	0.8-6	0.5-8	6-40	5-50
20	1-8	0.5-12	8-50	6-60
25	1.5-12	0.8-16	10-80	8-120
32	2-20	1.5-25	15-150	10-200
40	2.5-30	2-40	25-200	20-300
50	3-50	2.5-60	30-300	25-500
65	5-80	4-100	50-500	40-800
80	8-120	6-160	80-800	60-1200
100	12-200	8-250	120-1200	100-2000
125	20-300	12-400	160-1600	150-3000
150	30-400	18-600	250-2500	200-4000
200	50-800	30-1200	400-4000	350-8000
250	80-1200	40-1600	600-6000	500-12000
300	100-1600	60-2500	1000-10000	600-16000
400	200-3000	120-5000	1600-16000	1000-25000
500	300-5000	200-8000	2500-25000	1600-40000
600	500-8000	300-10000	4000-40000	2500-60000

• **Table 2 Saturated Steam Mass Flow Range Table (kg/h)**

Absolute Pressure (MPa)	0.2	0.3	0.4	0.5	0.6	0.7	0.8	
Temperature (°C)	120.2	133.5	143.62	151.84	158.94	164.96	170.41	
Density (kg/m ³)	1.129	1.651	2.163	2.669	3.17	3.667	4.162	
DN15	Qmin	5.645	8.255	10.815	13.345	15.85	18.335	20.81
	Qmax	56.45	82.55	108.15	133.45	158.5	183.35	208.1
DN20	Qmin	6.774	9.906	12.978	16.014	19.02	22.002	24.972
	Qmax	67.74	99.06	129.78	160.14	190.2	220.02	249.72
DN25	Qmin	9.032	13.208	17.304	21.352	25.36	29.336	33.296
	Qmax	135.48	198.12	259.56	320.28	380.4	440.04	499.44
DN32	Qmin	20.322	29.718	38.934	48.042	57.06	66.006	74.916
	Qmax	203.22	297.18	389.34	480.42	570.6	660.06	749.16
DN40	Qmin	22.58	33.02	43.26	53.38	63.4	18.335	83.24
	Qmax	338.7	495.3	648.9	800.7	951	1100.1	1248.6

Absolute Pressure (MPa)	0.2	0.3	0.4	0.5	0.6	0.7	0.8	
Temperature (°C)	120.2	133.5	143.62	151.84	158.94	164.96	170.41	
Density (kg/m³)	1.129	1.651	2.163	2.669	3.17	3.667	4.162	
DN50	Qmin	28.225	41.275	54.075	66.725	79.25	91.675	104.05
	Qmax	564.5	825.5	1081.5	1334.5	1585	1833.5	2081
DN65	Qmin	45.16	66.04	86.52	106.76	126.8	146.68	166.48
	Qmax	903.2	1320.8	1730.4	2135.2	2536	2933.6	3329.6
DN80	Qmin	67.74	99.06	129.78	160.14	190.2	220.02	249.72
	Qmax	1354.8	1981.2	2595.6	3202.8	3804	4400.4	4994.4
DN100	Qmin	112.9	165.1	216.3	266.9	317	366.7	416.2
	Qmax	2258	3302	4326	5338	6340	7334	8324
DN125	Qmin	169.35	247.65	324.45	400.35	475.5	550.05	624.3
	Qmax	3387	4953	6489	8007	9510	11001	624.3
DN150	Qmin	225.8	330.2	432.6	533.8	634	733.4	832.4
	Qmax	4516	6604	8652	10676	12680	14668	16648
DN200	Qmin	395.15	577.85	757.05	934.15	1109.5	1283.45	1456.7
	Qmax	9032	13208	17304	21352	25360	29336	33296
DN250	Qmin	564.5	825.5	1081.5	1334.5	1585	1833.5	2081
	Qmax	13548	19812	25956	32028	38040	44004	49944
DN300	Qmin	677.4	990.6	1297.8	1601.4	1902	2200.2	2497.2
	Qmax	18064	26416	34608	42704	50720	58672	66592

• Table 2 Saturated Steam Mass Flow Range Table (kg/h)

Absolute Pressure (MPa)	0.9	1.0	1.2	1.4	1.6	1.8	2.0	
Temperature (°C)	175.36	179.68	187.96	195.04	201.37	207.11	212.37	
Density (kg/m ³)	4.665	5.147	6.127	7.106	8.085	9.065	10.05	
DN15	Qmin	23.325	25.735	30.635	35.53	440.425	45.325	50.25
	Qmax	233.25	257.35	306.35	355.3	404.25	453.25	502.5
DN20	Qmin	27.99	30.882	36.762	42.636	48.51	54.39	60.3
	Qmax	279.9	308.82	367.62	426.36	485.1	543.9	603
DN25	Qmin	37.32	41.176	49.016	56.848	64.68	72.52	80.4
	Qmax	559.8	617.64	735.24	852.72	970.2	1087.8	1206
DN32	Qmin	83.97	92.646	110.286	127.908	145.53	163.17	180.9
	Qmax	839.7	926.46	1102.86	1279.08	1455.3	1631.7	1809
DN40	Qmin	93.3	102.94	122.54	142.12	161.7	181.3	201
	Qmax	1399.5	1544.1	1838.1	2131.8	2425.5	2719.5	3015
DN50	Qmin	116.625	128.675	153.175	177.65	202.125	226.625	251.25
	Qmax	2332.5	2573.5	3063.5	3553	4042.5	4532.5	5025
DN65	Qmin	186.6	205.88	245.08	284.24	323.4	362.6	402
	Qmax	3732	4117.6	4901.6	5684.8	6468	7252	8040
DN80	Qmin	279.9	308.82	367.62	426.36	485.1	543.9	603
	Qmax	5598	6176.4	7352.4	8527.2	9702	10878	12060
DN100	Qmin	466.5	514.7	1225.4	710.6	808.5	906.5	1005
	Qmax	9330	10294	12254	14212	16170	18130	20100
DN125	Qmin	699.75	772.05	919.05	1065.9	1212.75	18130	1507.5
	Qmax	699.75	15441	18381	21318	1617	27195	30150
DN150	Qmin	933	1029.4	1225.4	1421.2	1617	1813	2010
	Qmax	18660	20588	24508	28424	32340	36260	40200
DN200	Qmin	1632.75	1801.45	2144.45	2487.1	2829.75	3172.75	3517.5
	Qmax	37320	41176	49016	56848	64680	72520	80400
DN250	Qmin	2332.5	2573.5	3063.5	3553	4042.5	4532.5	5025
	Qmax	55980	61764	73524	85272	4851	108780	120600
DN300	Qmin	2799	3088.2	3676.2	4263.6	4851	5439	6030
	Qmax	74640	82352	98032	113696	129360	145040	160800

• Table 3 Superheated Steam Density & Relative Temperature and Pressure (Kg/m³)

Absolute Pressure (MPa)	Temperature (°C)					
	150	200	250	300	350	400
0.1	0.52	0.52	0.42	0.38		
0.15	0.78	0.70	0.62	0.57	0.52	0.49
0.2	1.04	0.93	0.83	0.76	0.69	0.65
0.25	1.31	1.16	1.04	0.95	0.87	0.81
0.33	1.58	1.39	1.25	1.14	1.05	0.97
0.35	1.85	1.63	1.46	1.33	1.22	1.13
0.4	2.12	1.87	1.68	1.52	1.40	1.29
0.5	-	2.35	2.11	1.91	1.75	1.62
0.6	-	2.84	2.54	2.30	2.11	1.95
0.7	-	3.33	2.97	2.69	2.46	2.27
0.8	-	3.83	3.41	3.08	2.82	2.60
1.0	-	4.86	4.30	3.88	3.54	3.26
1.2	-	5.91	5.20	4.67	4.26	3.92
1.5	-	7.55	6.58	5.89	5.36	4.93
2.0	-	-	8.968	7.97	7.21	6.62
2.5	-	-	11.5	10.1	9.11	8.33
3.0	-	-	14.2	12.3	11.1	10.1
3.5	-	-	17.0	14.6	13.0	11.8
4.0	-	-	-	17.0	15.1	13.6

8. Dimension

• Flange Connection Type

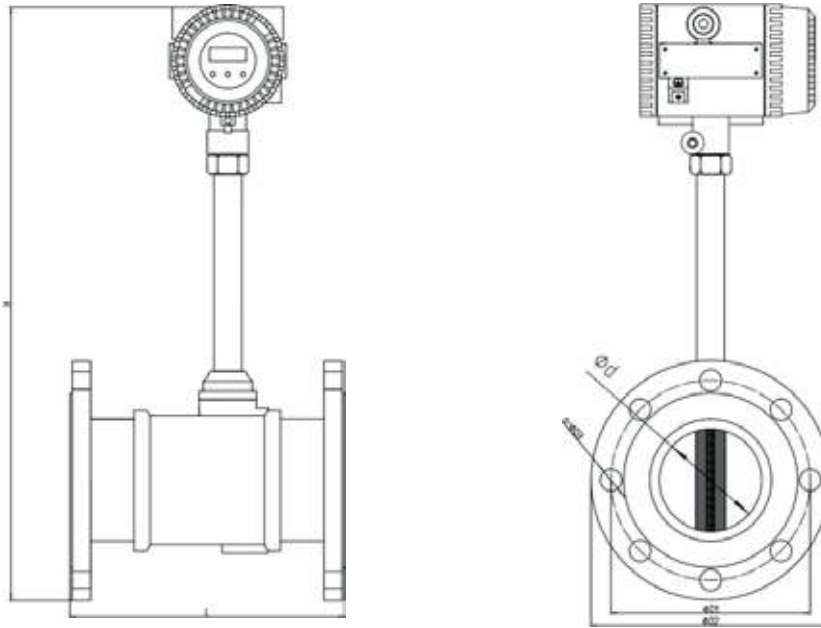

Size	L	H	d	D1	D2	n-D3
DN15	170	440	15	65	95	4-φ14
DN20	170	445	20	75	105	4-φ14
DN25	170	450	26	85	115	4-φ14
DN32	170	462	32	100	140	4-φ18
DN40	190	465	38	110	150	4-φ18
DN50	190	473	48	125	165	4-φ18
DN65	220	487	62	145	185	4-φ18
DN80	220	500	73	160	200	4-φ18
DN100	240	533	95	180	220	4-φ18
DN125	260	560	118	210	250	4-φ18
DN150	280	608	140	240	285	4-φ22
DN200	300	640	200	295	340	4-φ22
DN250	360	705	250	355	405	4-φ26
DN300	400	752	300	410	460	4-φ26

Note: Above dimension as per flange DIN PN16.

• Wafer Connection Type

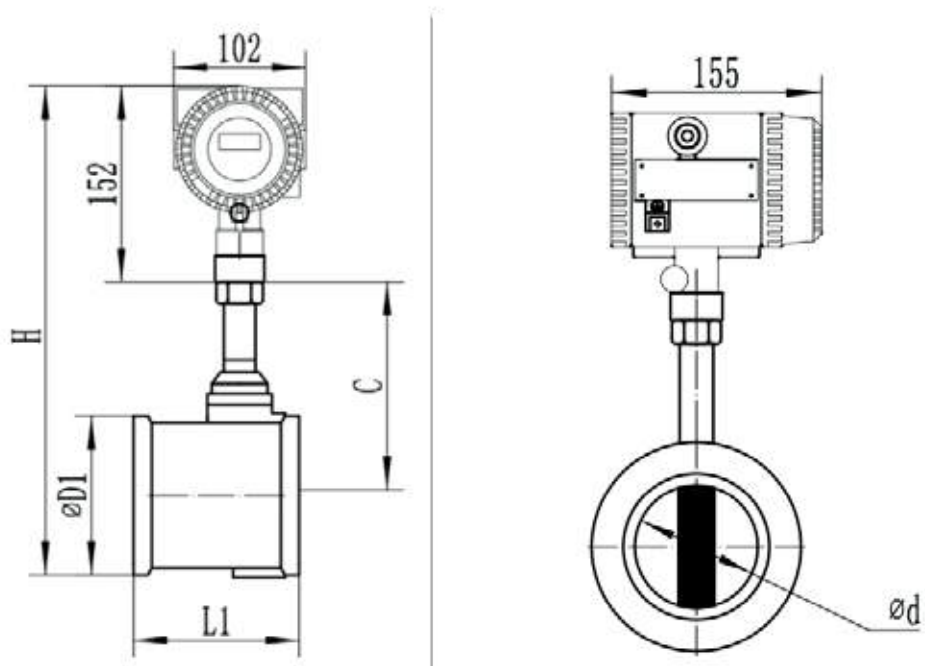

Size	L1	D1	d	C
DN15	65	65	15	240.5
DN20	65	65	20	240.5
DN25	65	65	26	240.5
DN32	65	65	32	240.5
DN40	80	76	38	237
DN50	80	88	48	237
DN65	92	101	62	242.5
DN80	100	112	73	247
DN100	124	134	95	271
DN125	145	158	118	248
DN150	165	180	140	313
DN200	195	247	200	319.5
DN250	115	300	250	348
DN300	130	347	300	369.5

• Insertion Type

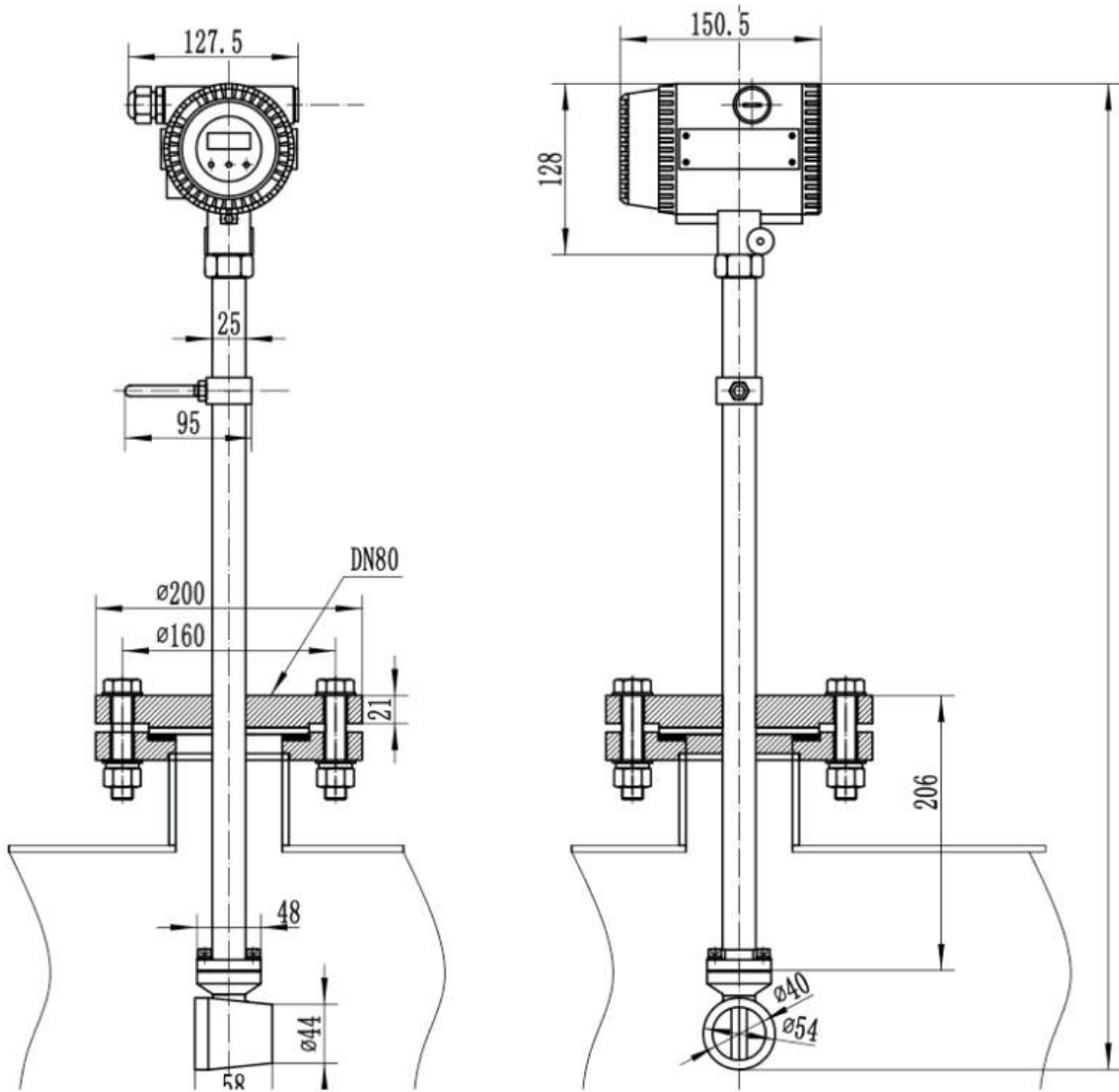

9. Vortex Flow Meter Installation

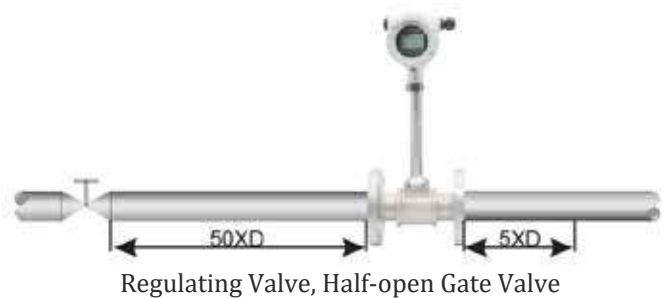
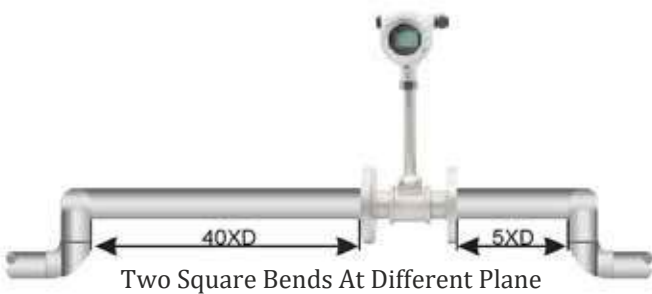
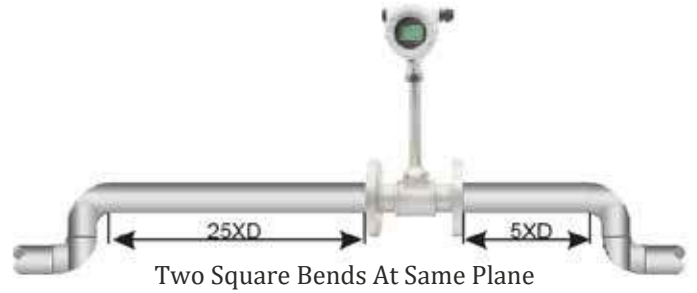
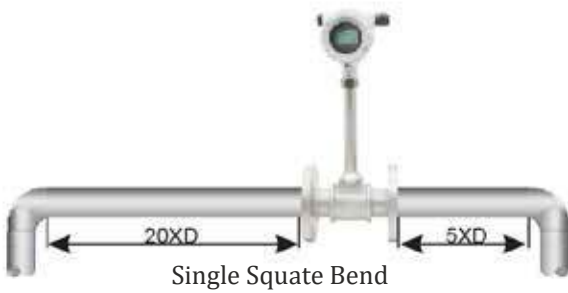
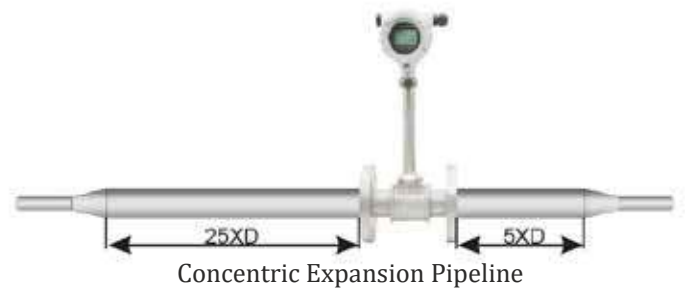
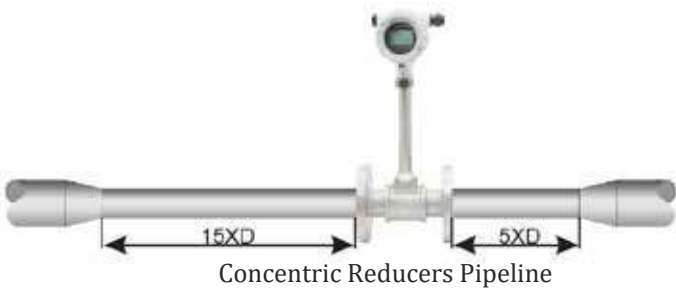

10. Model Selection Table

RF3400		x	x	x	x	x	x	x	x	x	x
Caliber	DN15-300mm/1/2"-12"										
Measured Medium	Saturated Steam		S								
	Superheated Steam		H								
	Common Gas		C								
	Liquid		L								
	Others		O								
Nominal Pressure	0.6MPa			1							
	1.0MPa			2							
	1.6MPa			3							
	2.5MPa			4							
	4.0MPa			5							
Nominal Temperature	(-)40°C~250°C				2						
	(-)40°C~350°C				3						
Structure	Compact type					C					
	Remote type (converter display)					R1					
	Remote type (flow computer remote display)					R2					
Connection	Flange(DN15-300mm)	PN10/PN16/PN25/PN40(DIN)				D**					
		A15:150#, A30:300# (ANSI)				A**					
	Wafer(DN15-300mm)					W					
	Thread(DN15-100mm)					T					
	Insertion(DN80-2000mm)					I					
Body Material	SS304 (standard)							4			
	SS316							6			
Compensation	Without								N		
	With temperature compensation								T		
	With pressure compensation								P		
	With temperature & pressure compensation								PT		
Output	4-20mA,pulse,RS485									A	
	4-20mA,pulse,HART									B	
Power Supply	DC24V										D
	3.6V Battery Powered										B
	AC220V (Remote flow computer type only)										A

Field Instrumentation Range



Pressure Measurement

- Smart Differential Pressure Transmitter
- Smart Gauge Pressure Transmitter
- Smart Absolute Pressure Transmitter
- Miniature Pressure Transducer without display
- Sanitary Gauge/ Absolute Pressure Transmitter

- Submersible Pressure Transmitter
- Remote Seal Differential P.T. with capillary
- Remote Seal Differential P.T. Direct Mount
- Remote Seal Gauge/Absolute P.T. with capillary
- Remote Seal Gauge/Absolute P.T. Direct Mount



Flow Measurement

- Coriolis Mass Flowmeter
- Thermal Gas Mass Flowmeter
- Positive Displacement Flowmeter
- Electromagnetic Flowmeter
- Vortex Flowmeter

- Turbine Flowmeter
- Variable Area Flowmeter
- Clamp On Ultrasonic Flowmeter
- Inline Ultrasonic Flowmeter
- Portable Ultrasonic Flowmeter



Level Measurement

- RADAR Level Transmitter Horn Antenna
- Compact RADAR Level Transmitter
- RADAR Level Transmitter Sanitary
- RADAR Level Transmitter
- Guided Wave RADAR Level Transmitter
- Guided Wave RADAR Level Transmitter
- RADAR Level Transmitter Lens Antenna

- RADAR Level Transmitter Rod Antenna
- Ultrasonic Level Transmitter
- Microwave Barrier Level Switch
- Admittance Level Switch Series
- Vibrating Rod Level Switch Series
- Tuning Fork Level Switch Series



Temperature Measurement

- Head Mount Temperature Transmitter
- Temperature Transmitter for Sanitary Applications

- DIN Rail Temperature Transmitter
- Field Mount Temperature Transmitter

Rocksensor India Pvt. Ltd.

📍 B -36, Sector 67, Noida, Uttar Pradesh - 201301

For more details, contact us on:

☎ +91 928 948 8117 | +91 1204121469

✉ info@rocksensor.in

🌐 www.rocksensor.in

Global Offices

Global HQ & R&D Centre:
Rocksensor Sàrl, Switzerland

North America:
Rocksensor Automation LLC, USA

APAC:
Rocksensor Automation Co. Ltd., Shanghai

For more updates, follow us on:

in: Rocksensor India

yt: Rocksensor

f: Rocksensor

ig: Rocksensor

tw: Rocksensor India