

Battery Powered Electromagnetic Flow Meter RF3300-B

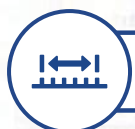

Line Size: DN10 ~ DN2000 mm



High accuracy and stability



RS485 MODBUS standard, HART, GPRS, PROFIBUS



Sensor Material: Battery Powered

**Product
Datasheet**

ROCKSENSOR AT A GLANCE (ABOUT US)

Rocksensor is one of the global leaders specializing in Process Instrumentation, Research and Development, and Designing of Industrial Automation Equipment. We provide highly precise pressure sensors and transmitters, flow metres, level transmitters, and temperature transmitters with a prime focus to help our clients efficiently, safely, and economically run complex industrial processes.

Rocksensor, headquartered in Switzerland has its footprint in various geographical regions such as the US, Russia, South Korea, Italy, Germany, Singapore, Malaysia, Morocco, China, Taiwan, Australia, UAE, Brazil, and India. Our clients come from some of the major industries such as Oil and Gas, Petrochemicals, Pharmaceuticals, FMCG, Automobiles, Water, Cement, Metal & Mining, and mainly from the Power Industry like Nuclear, Thermal, Hydro, and Solar.

Rocksensor deals in a wide range of highly accurate industrial automation instruments ensuring that even the complex industrial processes happen efficiently.

To fulfill the needs of our clients we make sure that our instruments work in even the harsh environmental conditions offering accurate recordings and communication.

We, at Rocksensor, believe in creating bonds that last a lifetime and create a success story for each and every client. Rocksensor aims to achieve a perfect fit in the global market landscape and establish our footprints across the globe.



CONTENTS

1. Description	3
2. Key Industries	3
3. Applications	3
4. Features	3
5. Technical Data.....	4
6. Measurement Mode.....	5
7. Dimensions	6
8. Communication	7
9. Process Connection.....	7
10. Electrode Material Compatibility with Application	8
11. Liner Material Compatibility with Application	8
12. Model Selection Table	9
13. Flow Range Table	10

KEY APPLICATION INDUSTRIES

- Effluent Treatment Plant
- Water Supply Scheme
- Food & Drug Industries
- Dairy Industries
- Textile Processing Industries
- Sewage Treatment Plant
- Steel & Aluminum Industries
- Chemical & Fertilizer Industries
- Sugar Industries

1. Description

RF3300-B Series battery-powered electromagnetic flow meter is an ideal flow measurement device for water and wastewater systems located at remote sites. Various signal and communication are available like, pulse, RS485, all real-time flow data can be monitored on computer or mobile phone by GPRS. Besides flow, it can also measure temperature or pressure. With 5 Nos. of 3.6V lithium battery, lifespan is up to 8 years, and battery can be changed as and when required. The transmitter housing is SS304 and the protection grade is IP68, which makes it suitable to be buried or submerged in the water.



2. Applications

- Raw Water
- Potable Water
- Sea Water
- Waste Water
- Industrial Heat Exchanger
- Acid Alkali Solution
- Cooling Water
- Irrigation

4. Features

- It has a long lifespan; standard battery can work for 3-8 years, determined by the excitation current. Exact battery life will depend upon the data frequency.
- Dual power supply: equipped with external power supply interface, which can be powered by external 12- 24VDC power supply, enabling users to have a variety of power options.
- Multiple work mode: RF3300-B has 'Flow Only' mode, 'Flow + Pressure' mode, 'Flow +Temperature' mode for users.
- Multiple network interfaces: RF3300-B has GPRS, RS485, HART and other network communication options for users.
- Replaceable 3.6V lithium battery.
- Infrared remote control display and operation.

5. Technical Data

Line Size	DN10 ~ DN2000 (3/8"~80")
Accuracy	±0.5% of reading at flow velocity ≥ 0.5m/s, ±0.2% optional at flow velocity≥0.5m/s
Velocity	0.1 ~ 15 m/s
Repeatability	≤0.17%
Structure	Compact / remote, cable length 10m standard, 100m max
Conductivity	>5 μS/cm, Demineralized Water >20 μS/cm
Protection Grade	Transmitter: IP65 standard, IP68 optional; Sensor: IP65 standard, IP68 (submersible, only available for remote type)
Electrode	SS316L, Hastelloy C, Hastelloy B, Titanium, Tantalum, Platinum-iridium
Power Supply	3.6V Lithium Battery
Power Consumption	<20W
Signal Output	4 ~ 20mA, Pulse
Communication Protocol	RS485 MODBUS standard, HART, GPRS, PROFIBUS optional
Display	LCD Display, 128X128 mm, three lines, 4 buttons
Ambient Temperature	(-)20°C ~ 60°C
Fluid Temperature	Compact: (-)20°C ~ 80°C; Remote: (-)20°C ~ 120°C
Liner Material	PTFE ((-)20°C ~ 150°C, DN15 ~ DN1600); FEP ((-)20°C ~ 120°C, DN3 ~ DN1800); PFA ((-)20°C ~ 160°C, DN3 ~ DN800); Polyurethane ((-)10°C ~ 60°C, DN40 ~ DN1600); Neoprene ((-)10°C ~ 80°C, DN40 ~ DN3000); Hard Rubber ((-)10°C ~ 80°C, DN40 ~ DN3000); Ceramic ((-)20°C ~ 180°C, DN15 ~ DN200)
Process connection	Flange, tri-clamp, wafer, thread, insertion
Sensor Material	Measuring tube: SS304 Flange & housing: carbon steel (standard), SS304 / SS316 optional
Transmitter Material	SS304
Nominal Pressure	Flange: PN10/ PN16/ PN25/ PN40 DIN/ 150#/ 300#/ 600# ANSI Others; Insertion, tri-clamp, wafer, thread: PN16
Display	Instantaneous flow, total flow, flow velocity
Function	High and low alarm, empty pipe alarm, exciting alarm, self-diagnosis
Totalizer	Three built-in totalizers: forward flow, reverse flow and net flow
Display Units	Unit L/s, L/m, L/h, m ³ /s, m ³ /m, m ³ /h, UKG, USG, gal/s, gal/m, gal/h, kg/s, kg/m, kg/h, t/s, t/m, t/h

6. Measurement Mode

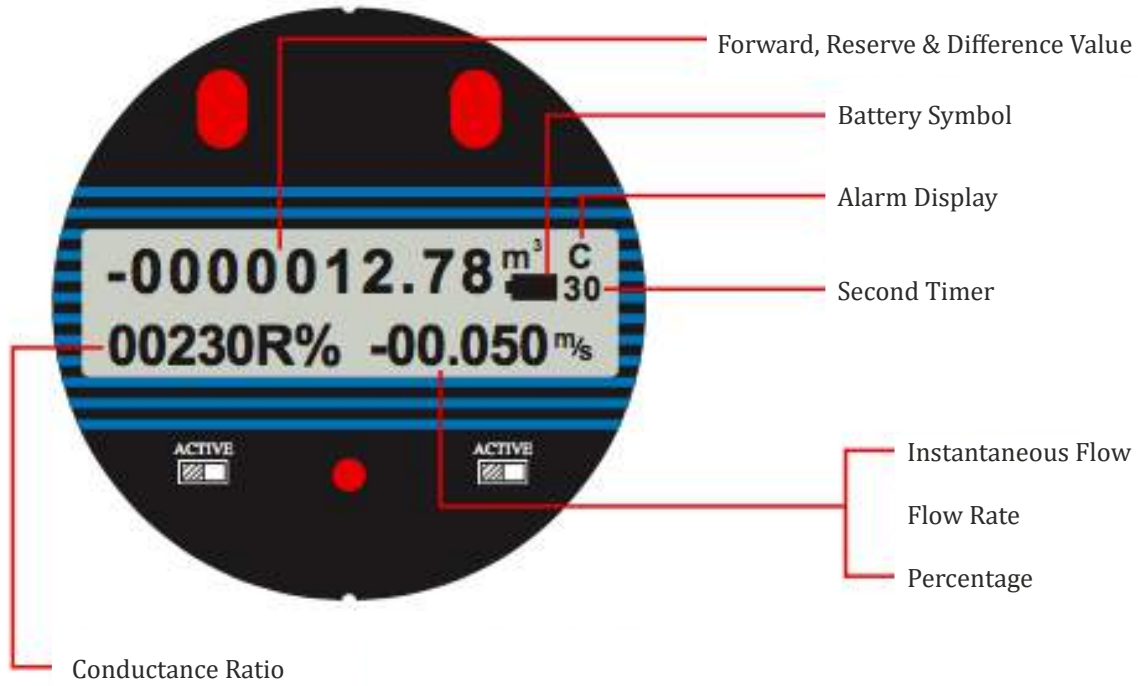

Flow Mode

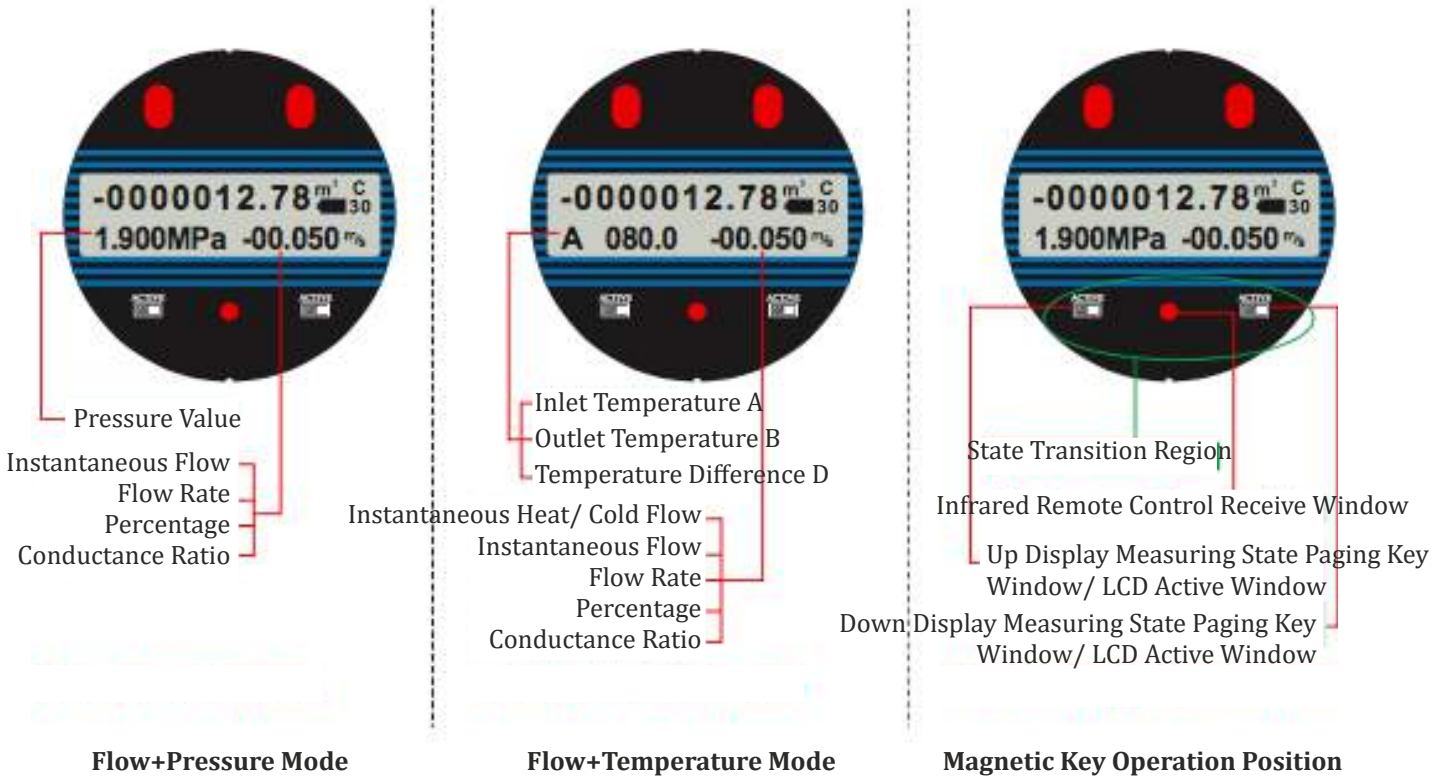

7. Dimensions

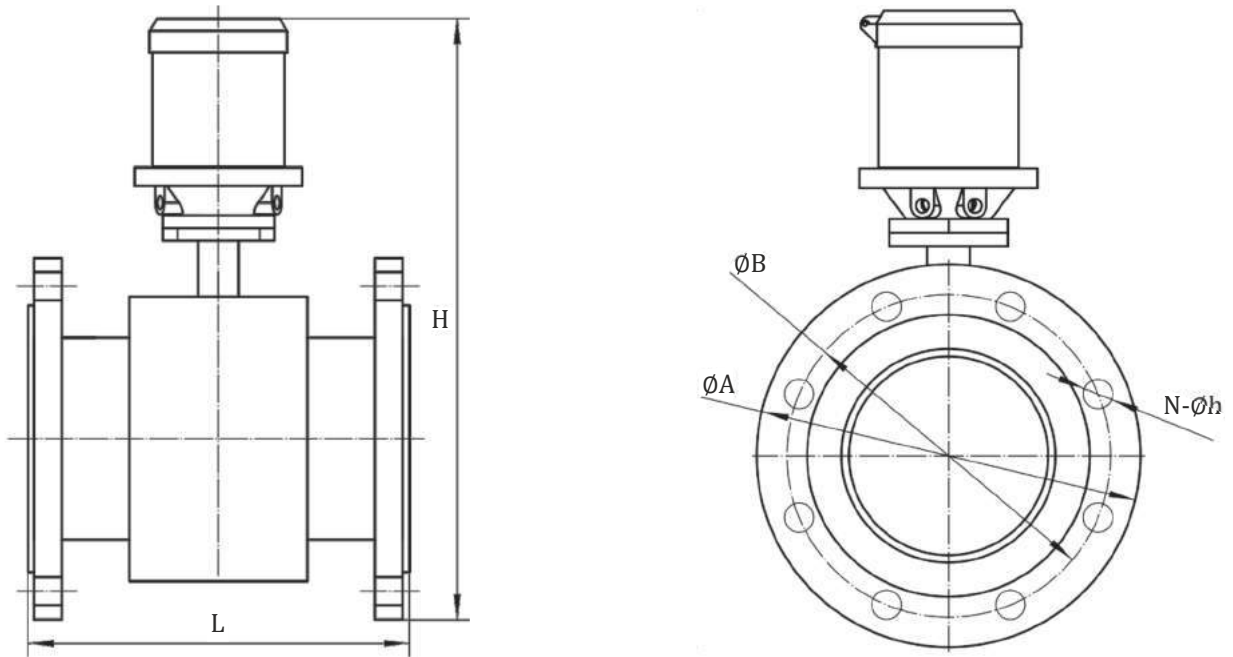

Size		Flange Standard	Nominal Pressure	H (mm)	L (mm)	φA (mm)	φB (mm)	φh (mm)	N (mm)
mm	mm								
DN15	1/2"	DIN	PN16	315	200	95	65	14	4
DN20	3/4"	DIN	PN16	320	200	105	75	14	4
DN25	1"	DIN	PN16	325	200	115	85	14	4
DN32	1¼"	DIN	PN16	337	200	140	100	18	4
DN40	1½"	DIN	PN16	347	200	150	110	18	4
DN50	2"	DIN	PN16	363	200	165	125	18	4
DN65	2½"	DIN	PN16	380	200	185	145	18	4
DN80	3"	DIN	PN16	396	200	200	160	18	8
DN100	4"	DIN	PN16	415	250	220	180	18	8
DN125	5"	DIN	PN16	440	250	250	210	18	8
DN150	6"	DIN	PN16	473	300	285	240	22	8
DN200	8"	DIN	PN16	530	350	340	295	22	12
DN250	10"	DIN	PN16	606	450	405	355	26	12
DN300	12"	DIN	PN16	659	500	460	410	26	12
DN350	14"	DIN	PN16	715	550	520	470	26	16
DN400	16"	DIN	PN16	770	600	580	525	30	16
DN450	18"	DIN	PN16	826	600	640	585	30	20
DN500	20"	DIN	PN16	889	600	715	650	33	20
DN600	24"	DIN	PN16	1007	600	840	770	36	20
DN700	28"	DIN	PN16	1093	700	910	840	36	24
DN800	32"	DIN	PN16	1201	800	1025	950	39	24
DN900	36"	DIN	PN16	1301	900	1125	1050	39	28
DN1000	40"	DIN	PN16	1426	1000	1255	1170	42	28

8. Communication



Standard Battery powered without output signal



Standard Battery powered with pulse



Standard Battery powered with RS485 MODBUS



Standard Battery powered with external GPRS

9. Process Connection



Flange



Insertion



Tri-clamp



Thread



Remote

10. Electrode Material Compatibility with Application

Electrode Material	Application
SS316L	Applicable to industrial and municipal water, wastewater and low corrosive mediums. Widely used in petroleum, chemical industries.
Hastelloy B	Strong resistance to hydrochloric acids below the boiling point. Resist against oxidable acids, alkali and non-oxidable salts, like vitriol, phosphate, hydrofluoric acids & organic acids.
Hastelloy C	Exceptional resistance to strong solutions of oxidizing salts and acids, like Fe ⁺⁺⁺ , Cu ⁺⁺ , Nitric acids, mixed acids.
Titanium	Titanium can withstand corrosive mediums such as seawater, chloride salt solutions, hypochlorite salts, oxidable acids (including fuming nitric acids), organic acids, and alkali. Not resistant to high purity reducing acids such as sulphuric acids, hydrochloric acids.
Tantalum	Highly resistant to corrosive mediums. Applicable to all chemical mediums except Hydrofluoric Acids, Oleum and Alkali.
Platinum-Iridium	Applicable to all chemical mediums except for Ammonium salts and Fortis.

11. Liner Material Compatibility with Application

Liner Material	Application
PTFE	Best chemical resistance, withstand boiling hydrochloric acid, sulfuric acid, nitric acid, alkali and a variety of organic solvents. Poor wear resistance and poor adhesion.
PFA	Highly resistant to chemicals. Performance well under vacuum pressure condition
Neoprene	Excellent elasticity, good abrasion resistance. Withstand the corrosion of low-concentration acid, alkali, salt and other media. Not resistant to corrosion by oxidizing medium.
Polyurethane	Strong abrasion resistant, applicable for slurries and muds. Poor corrosion resistance, can't be used for corrosive medium
Hard Rubber	Withstand the corrosion of hydrochloric acid, acetic acid, oxalic acid, ammonia water, phosphoric acid and 50% sulfuric acid, sodium hydroxide, potassium hydroxide. Use for general acid, alkali, and salt solutions, not resistant to the corrosion of strong oxidants
Ceramic	Withstands high temperature, corrosion and wear Smooth inner, totally vacuum resistant

12. Lining Material Temperature Limit

Lining Material	Flange Material	Min. Temperature	Max. Temperature	
			Standard	High Temperature
Hard Rubber	Steel	(-)10°C (14°F)	90°C (194°F)	
	Stainless Steel	(-)15°C (5°F)	90°C (194°F)	
Soft Rubber	Steel	(-)10°C (14°F)	60°C (140°F)	
	Stainless Steel	(-)15°C (5°F)	60°C (140°F)	
PTFE/ ETFE	Steel	(-)10°C (14°F)	130°C (266°F)	
	Stainless Steel	(-)25°C ((-)13°F)	130°C (266°F)	
Thick PTFE/ PFA	Steel	(-)10°C (14°F)	130°C (266°F)	180°C (356°F)
	Stainless Steel	(-)25°C ((-)13°F)	130°C (266°F)	180°C (356°F)
Ceramic Carbide	Steel	(-)10°C (14°F)	80°C (176°F)	
	Stainless Steel	(-)20°C ((-)4°F)	80°C (176°F)	

13. Flow Range Table

Size		Flow Range & Velocity Table							
mm	Inch	0.1 m/s	0.2 m/s	0.5 m/s	1 m/s	4 m/s	10 m/s	12 m/s	15 m/s
DN3	1/8"	0.003	0.005	0.013	0.025	0.102	0.254	0.305	0.382
DN6	1/4"	0.01	0.02	0.051	0.102	0.407	1.017	1.221	1.526
DN10	3/8"	0.028	0.057	0.141	0.283	1.13	2.826	3.391	4.239
DN15	1/2"	0.064	0.127	0.318	0.636	2.543	6.359	7.63	9.538
DN20	3/4"	0.113	0.226	0.565	1.13	4.522	11.304	13.56	16.956
DN25	1"	0.177	0.353	0.883	1.766	7.065	17.663	21.2	26.494
DN32	1¼"	0.289	0.579	1.447	2.894	11.575	28.938	34.73	43.407
DN40	1½"	0.452	0.904	2.261	4.522	18.086	45.216	54.26	67.824
DN50	2"	0.707	1.413	3.533	7.065	28.26	70.65	84.78	105.98
DN65	2½"	1.19	2.39	5.97	11.94	47.76	119.4	143.3	179.1
DN80	3"	1.81	3.62	9.04	18.09	72.35	180.86	217	271.3
DN100	4"	2.83	5.65	14.13	28.26	113.04	282.6	339.1	423.9
DN125	5"	4.42	8.83	22.08	44.16	176.63	441.56	529.9	662.34
DN150	6"	6.36	12.72	31.79	63.59	254.34	635.85	763	953.78
DN200	8"	11.3	22.61	56.52	113.04	452.16	1130.4	1356	1696
DN250	10"	17.66	35.33	88.31	176.53	706.5	1766.25	2120	2649
DN300	12"	25.43	50.87	127.2	254.34	1017	2543.4	3052	3815
DN350	14"	34.62	69.24	1731	3461.9	1385	3461.85	4154	5193
DN400	16"	45	90	2261	452	1809	4522	5426	6782
DN450	18"	57	114	2861	572	2289	5723	6867	8584
DN500	20"	71	141	3533	707	2826	7065	8478	10598
DN600	24"	102	203	5087	1017	4069	10174	12208	15260
DN700	28"	138	277	6924	1385	5539	13847	16617	20771
DN800	32"	181	362	9043	1809	7235	18086	21704	27130
DN900	36"	229	458	1145	2289	9156	22891	27469	34336
DN1000	40"	283	565	1413	2826	11304	28260	33912	42390
DN1200	48"	407	814	2035	4069	16278	40694	48833	61042
DN1400	56"	554	1108	2769	5539	22156	55390	66468	83084
DN1600	64"	723	1447	3617	7235	28938	72346	86815	108518
DN1800	72"	916	1831	4578	9156	36625	91562	109875	137344
DN2000	80"	1130	2261	5652	11304	45216	113040	135648	169560
DN2200	88"	1368	2736	6839	13678	54711	136778	164134	205168
DN2400	96"	1628	3256	8139	16278	65111	162778	195333	244166
DN2600	104"	1910	3821	9552	19104	76415	191038	229245	286556
DN2800	112"	2216	4431	11078	22156	88623	221558	265870	332338
DN3000	120"	2543	5087	12717	25434	101736	254340	305208	381510

12. Model Selection Table

RF3300-B	Battery Powered Electromagnetic Flowmeter															
Code	1	2	3	4	5	6	7	8	9	10						
Caliber Size	DN10 ~ DN2000 (3/8" ~ 80")															
Structure	Compact	1									Remote	2				
Lining Material	PTFE	1	FEP	2	PFA	3	Neoprene	4	Polyurethane	5	Hard Rubber	6	Ceramic	7	Others	8
Electrode Material	SS316L	1	Hastelloy B	2	Hastelloy C	3	Titanium	4	Tantalum	5	Platinum-iridium	6	Stainless steel covered with tungsten carbide	7	Others	8
Body Material (Sensor Housing)	Carbon Steel	1	SS304	2	SS316	3										
Measuring Mode	1	Flow	2	Flow + Temperature	3	Flow + Pressure										
Flange Material	1	Carbon Steel	2	SS304	3	SS316										
Process Connection (Flange)	D**	DIN D10: DIN PN10, D16: DIN PN16, D25: DIN PN25, D40: DIN PN40			A**	ANSI A15: ANSI 150#, A30: ANSI 300#, A60: ANSI 600#			O	Others						
Process Connection (Insertion)	IT	G2" thread ball valve			IF	DN50 flange ball valve										
Process Connection	TC	Tri-clamp			W	Wafer			T	Thread						
Signal Output/ Communication	P	Pulse			R	RS485			G	GPRS	H	HART (24VDC only)		4	4-20 mA (need external power)	
Power Supply	1	3.6V lithium battery			2	3.6V lithium battery & 12 ~ 24VDC			3	3.6V lithium battery & 85 ~ 265VAC						

15. Installations Precautions

- Installations locations should be such that Flowmeter will always remain full with liquid.
- A minimum 5D upstream & 2D downstream straight lengths should be maintained at installation locations, where D is the pipe diameter.
- The Flowmeter installation location should be free of bends, elbows, tees, valves, etc.
- It is recommended to install a flowmeter at the rear end of the pump outlet to avoid the bubble stay.
- Avoid installation of Flowmeter at the inlet, to avoid negative pressure inside the pipe.
- An all-weather cover should be used to prevent the housing from the direct sunlight or rain when the device in outdoors.

16. Installations Requirements

- The sensor can be installed either on a straight pipe or on a horizontal or inclined pipe, but it requires that the central connection of the two electrodes be horizontal.

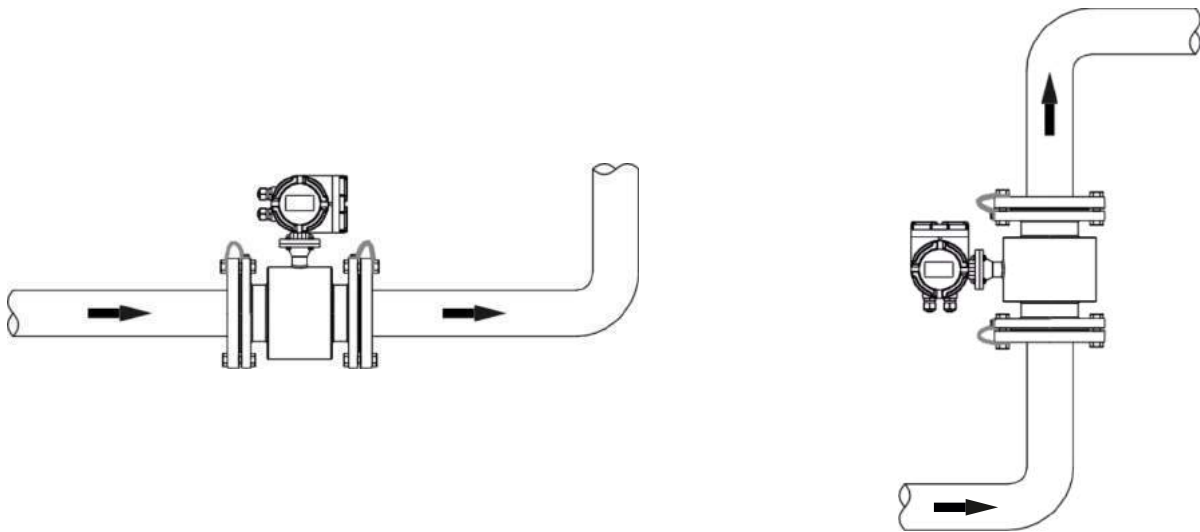

Installation in horizontal or vertical pipeline

- The front and rear straight pipe sections are the wiring of the flow meter $\geq 5DN$ at the front of the flow meter and the rear $\leq 3DN$

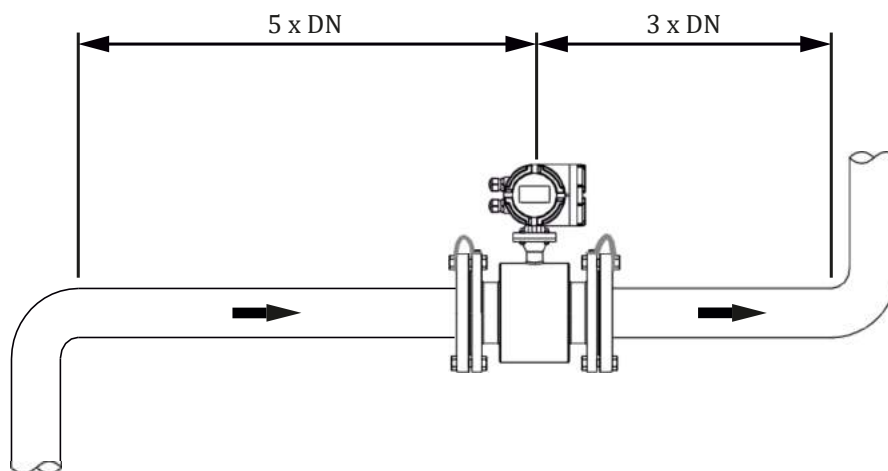

Requirement to install the flowmeter straight pipes

- The electromagnetic flowmeter must be installed so that the pipe is always completely filled with fluid. In a partially filled pipe case, the flowmeter must be installed with the siphon phenomenon, for which the pipe stretch where the meter is installed is kept always full.

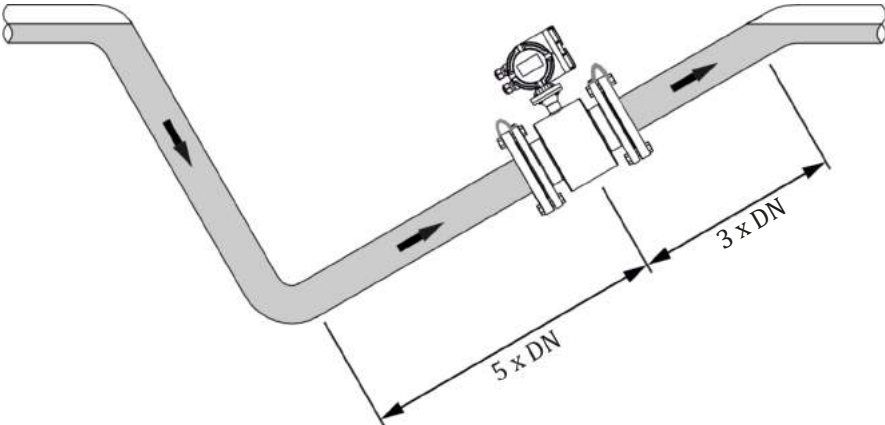

Installation in partially filled pipes

- Install a siphon (a) with a vent valve (b) downstream of the sensor in down pipes longer than 5 meters. This precaution is to avoid low pressure and the consequent risk of damage to the lining of the measuring tube.

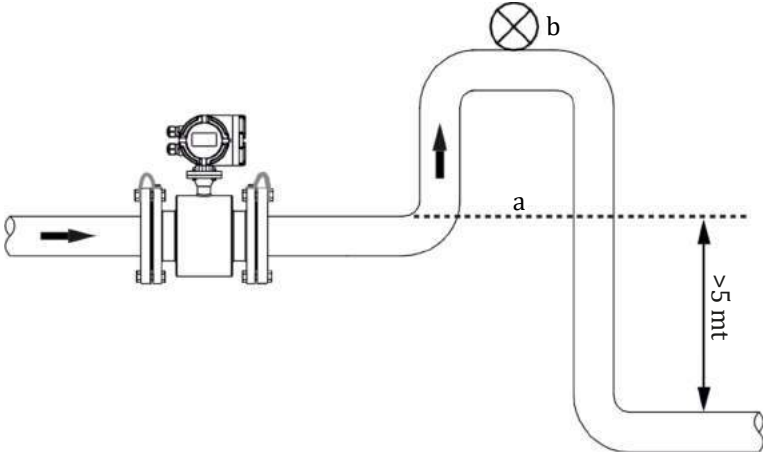

Installation in proximity of a > 5m down pipe section

- The electromagnetic flowmeter must not be installed in the pipe section with a free pipe outlet that could run empty. When installing in a downstream pipe, please make sure the pipe is always fully filled with medium.

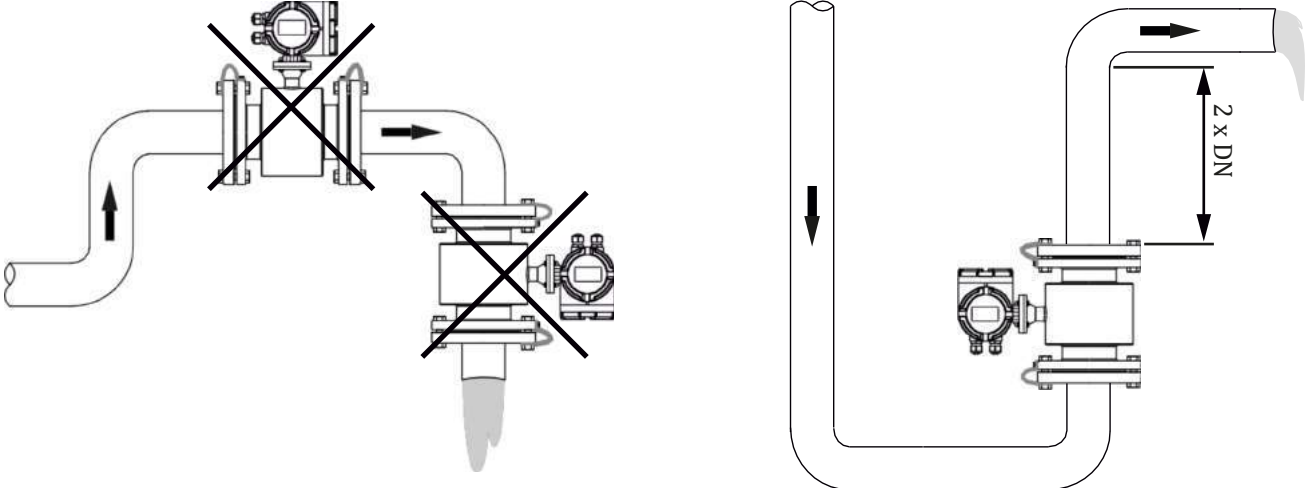

Installation in pipe without emptying

- The electromagnetic flowmeter can not be installed at the pipe highest point, because air or gas accumulations may occur in the measuring pipe.

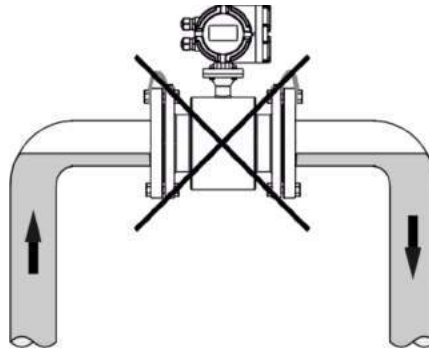

Installation at highest point

- The electromagnetic flowmeter can not be installed upstream of a pump to prevent cavitation, which can damage the sensor lining.

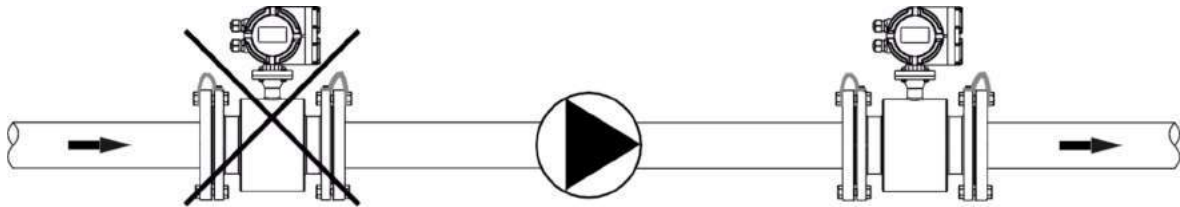

Near pumps installation

17. Pipe Connection

The sensor itself can not be as its support, it should be supported to the connecting pipes. And the sensor should not withstand too big fastening stress. It should be taken into account to eliminate the stress caused by thermal expansion.

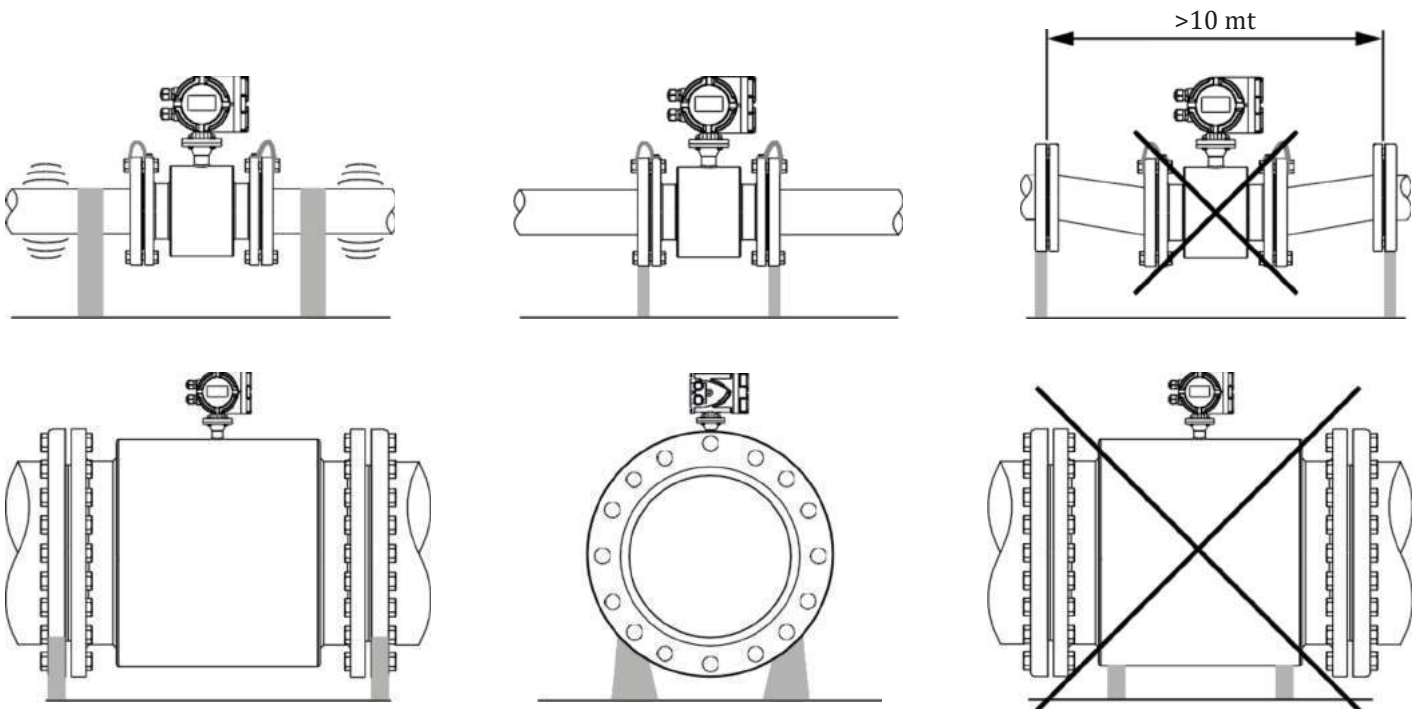

Field Instrumentation Range



Pressure Measurement

- Smart Differential Pressure Transmitter
- Smart Gauge Pressure Transmitter
- Smart Absolute Pressure Transmitter
- Miniature Pressure Transducer without display
- Sanitary Gauge/ Absolute Pressure Transmitter
- Submersible Pressure Transmitter
- Remote Seal Differential P.T. with capillary
- Remote Seal Differential P.T. Direct Mount
- Remote Seal Gauge/Absolute P.T. with capillary
- Remote Seal Gauge/Absolute P.T. Direct Mount



Flow Measurement

- Coriolis Mass Flowmeter
- Thermal Gas Mass Flowmeter
- Positive Displacement Flowmeter
- Electromagnetic Flowmeter
- Vortex Flowmeter
- Turbine Flowmeter
- Variable Area Flowmeter
- Clamp On Ultrasonic Flowmeter
- Inline Ultrasonic Flowmeter
- Portable Ultrasonic Flowmeter



Level Measurement

- RADAR Level Transmitter Horn Antenna
- Compact RADAR Level Transmitter
- RADAR Level Transmitter Sanitary
- RADAR Level Transmitter
- Guided Wave RADAR Level Transmitter
- Guided Wave RADAR Level Transmitter
- RADAR Level Transmitter Lens Antenna
- RADAR Level Transmitter Rod Antenna
- Ultrasonic Level Transmitter
- Microwave Barrier Level Switch
- Admittance Level Switch Series
- Vibrating Rod Level Switch Series
- Tuning Fork Level Switch Series



Temperature Measurement

- Head Mount Temperature Transmitter
- Temperature Transmitter for Sanitary Applications
- DIN Rail Temperature Transmitter
- Field Mount Temperature Transmitter

Rocksensor India Pvt. Ltd.

📍 B -36, Sector 67, Noida, Uttar Pradesh - 201301

For more details, contact us on:

☎ +91 928 948 8117 | +91 1204121469

✉ info@rocksensor.in

🌐 www.rocksensor.in

Global Offices

Global HQ & R&D Centre:
Rocksensor Sàrl, Switzerland

North America:
Rocksensor Automation LLC, USA

APAC:
Rocksensor Automation Co. Ltd., Shanghai

For more updates, follow us on:

in: Rocksensor India

▶: Rocksensor

f: Rocksensor

📷: Rocksensor

🐦: Rocksensor India