

Coriolis Mass Flow Meter

RF3200



True Mass flow measurement



High accuracy density measurement



Fast & Uncomplicated commissioning



Compact/ Integrated design

**Product
Datasheet**

ROCKSENSOR AT A GLANCE (ABOUT US)

Rocksensor is one of the global leaders specializing in Process Instrumentation, Research and Development and Designing of Industrial Automation Equipment. We provide highly precise pressure sensors and transmitters, flow metres, level transmitters and temperature transmitters with a prime focus to help our clients efficiently, safely and economically run complex industrial processes.

Rocksensor, headquartered in Switzerland, has its footprint in various geographical regions such as the US, Russia, South Korea, Italy, Germany, Singapore, Malaysia, Morocco, China, Taiwan, Australia, UAE, Brazil and India. Our clients come from some of the major industries such as Oil and Gas, Petrochemicals, Pharmaceuticals, FMCG, Automobiles, Water, Cement, Metal & Mining, and mainly from the Power Industry like Nuclear, Thermal, Hydro, and Solar.

Rocksensor deals in a wide range of highly accurate industrial automation instruments ensuring that even the complex industrial processes happen efficiently.

To fulfill the needs of our clients we make sure that our instruments work in even the harsh environmental conditions offering accurate recordings and communication.

We, at Rocksensor, believe in creating bonds that last a lifetime and create a success story for each and every client. Rocksensor aims to achieve a perfect fit in the global market landscape and establish our footprints across the globe.



CONTENTS

1. Introduction	3
2. Key Applications	3
3. Working Principle	4
4. Advantage	6
5. Salient Features	6
6. RF3200 Coriolis Mass Flow Meter Types	7
7. Technical Parameter	8
8. Flow Rate Table	9
9. Diagram	10
10. Model Selection Table	11
11. Installation	12
12. Electrical Connections	12

KEY APPLICATION INDUSTRIES

- Oil and Gas sector
- Cement
- Metal
- Pulp and Paper
- Agriculture
- Textiles
- Chemicals
- Power
- Water
- Pharmaceutical
- Fertilizer
- Plastics and HVAC

1. Introduction

RF3200 Coriolis Mass Flowmeter: Coriolis mass flow meters are the leading precision flow and density measurement solution, offering the most accurate and repeatable mass flow measurement for liquids, slurries and Gases. The Coriolis flowmeters offer the reliable measurement available for virtually any process fluid, while exhibiting exceptionally low pressure drop.

2. Key Applications

- Diesel, Petrol, clean liquid (Low Viscous liquid)
- Chemicals
- Acids
- Caustic
- Water
- LPG & CNG (Custody transfer)
- Gases/vapours
- Inlet air & fuel
- Inlet water to boiler
- Oil



Normal (RF3200-T)



Cryogenic (RF3200-L)



Ultra-High (RF3200-P)



Sanitary (RF3200-W)



Natural Gas (RF3200-G)

3. Working Principle

A Coriolis flow meter is based on the principles of motion mechanics. When the process fluid enters the sensor, it splits. During operation, a drive coil stimulates the tubes to oscillate in opposition at the natural resonant frequency. As the tubes oscillate, the voltage generated from each pickoff creates a sine wave. This indicates the motion of one tube relative to the other. The time delay between the two sine waves is called Delta-T, which results to generate differential voltage Delta- V which is directly proportional to the mass flow rate.

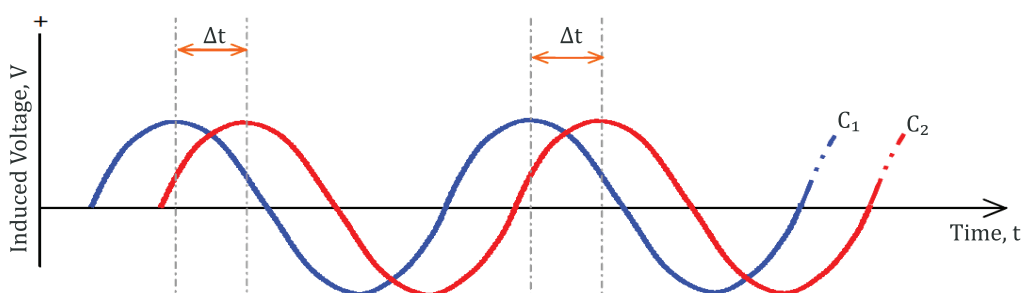

4. Advantages

Key benefit of Coriolis flow meters is their ability to perform multiple measurements. In addition to measuring mass flow directly, Coriolis meters also measure the density of the process by monitoring the duration of the tube's vibration and characterizing it as a density.

- True Mass flow measurement with accuracy up to 0.1%.
- Highly accurate density measurement up to $\pm 0.001 \text{g/cm}^3$ ($\pm 1 \text{kg/m}^3$).
- Measure mass flow directly without being affected by temperature, pressure, flow rate, viscosity etc.
- Display mass flow-rate, volume flow-rate, temperature and density parameters.
- No inlet and outlet sections required.
- No straight pipe run required.
- Fast and Uncomplicated commissioning.
- Compact/Integrated design and easy installation.
- On side zero and span calibration

5. Salient Features

Coriolis meters are applied in a wide variety of applications,

- Line sizes 250mm (10") and smaller
- 300 ANSI through 900 ANSI
- High turndown requirements
- Dirty, wet, or sour gas where maintenance can be an issue with other technologies
- There is no room for long straight runs
- Changing gas composition and density
- Sudden changes in gas flow velocity (fuel gas applications) and applications where abnormally high flow rates can occur.
- Pulsating gas flows (fuel gas and compression gas in the use of reciprocating compressors)

6. RF3200 Coriolis Mass Flow Meter Types



(RF3200-T) Solution for Process Industry

- Not affected by physical properties such as viscosity and density of liquid.
- Integrated design, small size, easily installed.
- Degree of Protection: IP67.
- No movable parts inside for long working life.



(RF3200-L) Cryogenic Liquid (LPG)

- Accurate and stable measurement is implemented by the high precise digital signal process.
- Compact design, small size, reliable performance, longer service life.
- Degree of Protection: IP67.
- Suitable for Cryogenic liquids temperature up to (-)196°C



(RF3200-T) Solution for Process Industry

- U-tube low-frequency design, excellent flow measurement performance, are more in line with the precise measurement of the use of hydrogenation machine condition;
- The main parts are made of anti-hydrogen embrittlement 55 materials, and the welds are treated by special processes, which have excellent anti-hydrogen embrittlement performance;

**(RF3200-W) high sanitary situation requirement**

- No dead angle, easily cleaned; save space, easily installed. Do not need maintenance.
- Excellent quake resistance performance.
- Measurement performance is not affected by medium properties.
- Can be used for CIP/SIP cleaning.

**(RF3200-G) Natural Gas (CNG/other natural gases)**

- U type single bend thick wall tube and intermediate frequency design to effectively guarantee the zero point stability in the case of multi impurity and multi component
- Using the conventional SS316L material, Smooth tube without other components. There is no additional pressure loss during measuring process.

7. Technical Specifications

Line size	DN (mm) 3 ~ 250
Medium temperature	RF3200-T: (-)40°C ~ 150°C RF3200-W: (-)40°C ~ 150°C RF3200-P: (-)40°C ~ 70°C RF3200-L: (-)196°C ~ 70°C RF3200-G: (-)40°C ~ 150°C
Ambient temperature	(-)40°C ~ 55°C, With display: (-)25°C ~ 70°C
Relative humidity	≤95%
Working Temperature	((-)20 ~ 55)°C
Storage Temperature	((-)20 ~ 70)°C
Measurement medium	Gas, liquid, uniform multiphase flow
Power supply	12VAC ~ 30VAC/ 15VDC ~ 40VDC
Vibration limit	Confirm to IEC/ T 2423.10, use 5 ~ 55Hz frequency sweep, amplitude 0.35mm, sweep frequency 5 times on three mutually perpendicular each axis
Accuracy	±0.5% (Standard), ±0.15% ±0.2
Optional Repeatability	0.25% (Standard), 0.075%, 0.1%
Optional Range ratio	20:1
Density accuracy	±0.001g/cm ³ (±1kg/m ³)
Temperature accuracy	±1°C ± 0.5% × measured value
Temperature repeatability	0.2°C
Output signals	4-20mA current loop, pulse
Communication	HART/ Modbus/ RS-485
Electrical connections	The end of the cable to the customer site is a M20 × 1.5 lead
Sensor	Micro-bend type, Explosion-proof
Protection	IP67, Explosion Proof
Sensor & Body Material	SS316L/SS304/SS304L
Circulation time	50 times

8. Flow Rate Table

DN	Max. Flow range (kg/h)	Normal flow range for 0.1% accuracy (Kg/h)	Normal flow range for 0.2% accuracy (Kg/h)	Normal flow range for 0.5% accuracy (Kg/h)	Stability of Zero point (Kg/h)
3	1.2~120	10~120	8~120	6~120	0.004
8	8~800	80~800	55~800	40~800	0.035
10	10~1000	100~1000	70~1000	50~1000	0.045
15	20~3000	300~3000	200~3000	150~3000	0.09
25	80~8000	600~8000	400~8000	300~8000	0.25
40	240~24000	2400~24000	1200~24000	1000~24000	1
50	500~45000	5000~45000	2500~45000	2000~45000	2
80	800~120000	10000~120000	8000~120000	6000~120000	3.5
100	1500~200000	20000~200000	15000~200000	10000~200000	7
150	5000~500000	50000~500000	35000~500000	30000~500000	23
200	10000~1000000	100000~1000000	70000~1000000	50000~1000000	45
250	15000~1500000	150000~1500000	120000~1500000	75000~1500000	70

Stability:

0.1%	0.2%	0.5%
Stability of Zero Point	Stability of Zero Point	Stability of Zero Point
$\pm 0.1\%$ (Instantaneous Flow \times 100%)	$\pm 0.2\%$ (Instantaneous Flow \times 100%)	$\pm 0.5\%$ (Instantaneous Flow \times 100%)
Accuracy is calculated based on the water measurement under the condition of +20°C ~ 25°C and 0.1MPa ~ 0.2MPa.		

Measurement of temperature:

Temperature Range	((-)50 ~ 125)°C	Integrated Type
	((-)50 ~ 200)°C	Separate Type
	((-)50 ~ 350)°C	High Temperature Separate Type
	((-)200 ~ 125)°C	Low Temperature Separate Type
Basic Error	$\leq \pm 1.0^\circ\text{C}$	

Measurement of Density:

Density Range	(0.2 ~ 2.0)g/cm ³
Basic Error	$\pm 0.002\text{g/cm}^3$ (Affected by the sensor)
Repeatability	0.001g/cm ³

9. Diagram

Size:

For detailed process connection dimensions, please refer to the previous "Process Connection". The following figure shows the factory default standard process connection. At the same time, we provide customers with optional process connection types.

The dimensions are in millimeters. Error: $\pm 2\text{mm}$

RF3200-08P:

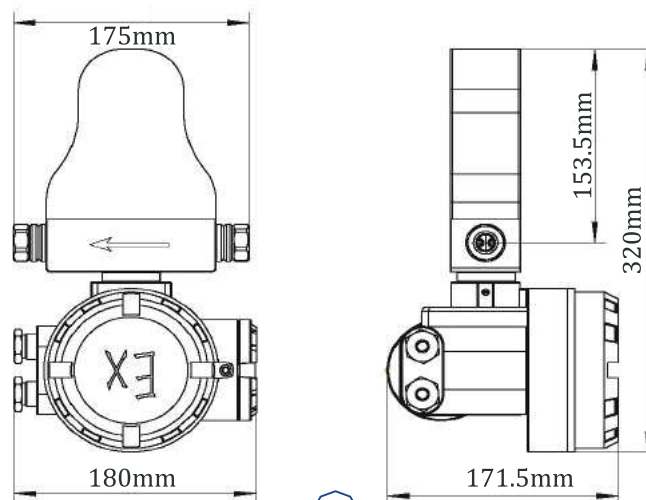

RF3200-15P:

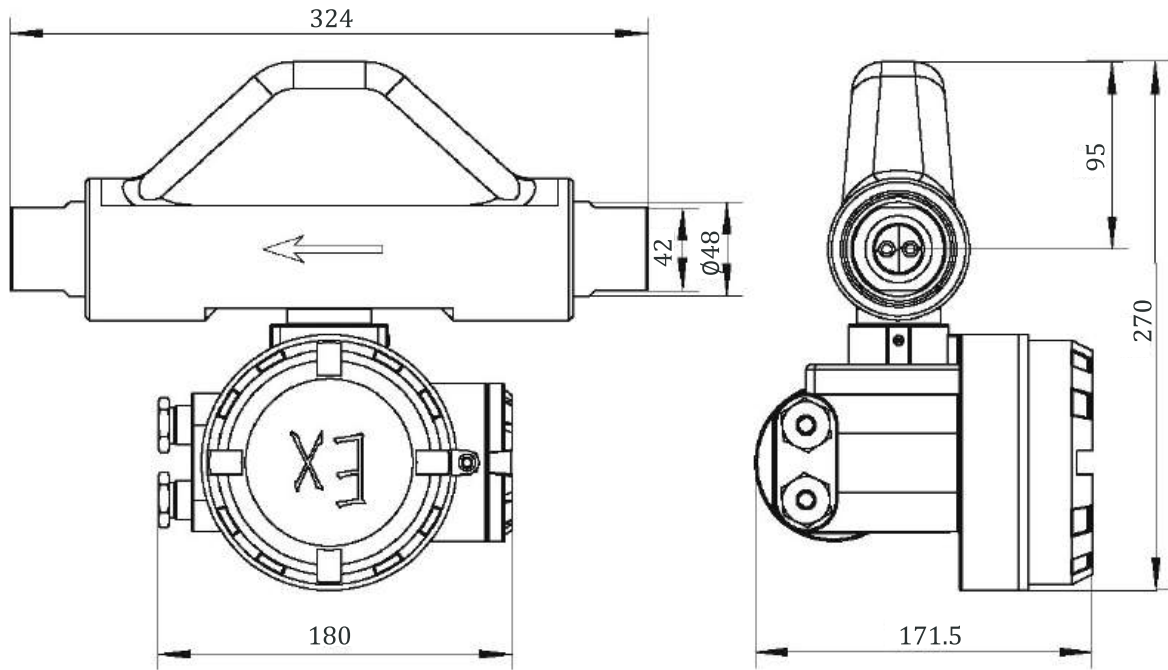

RF3200-08L:

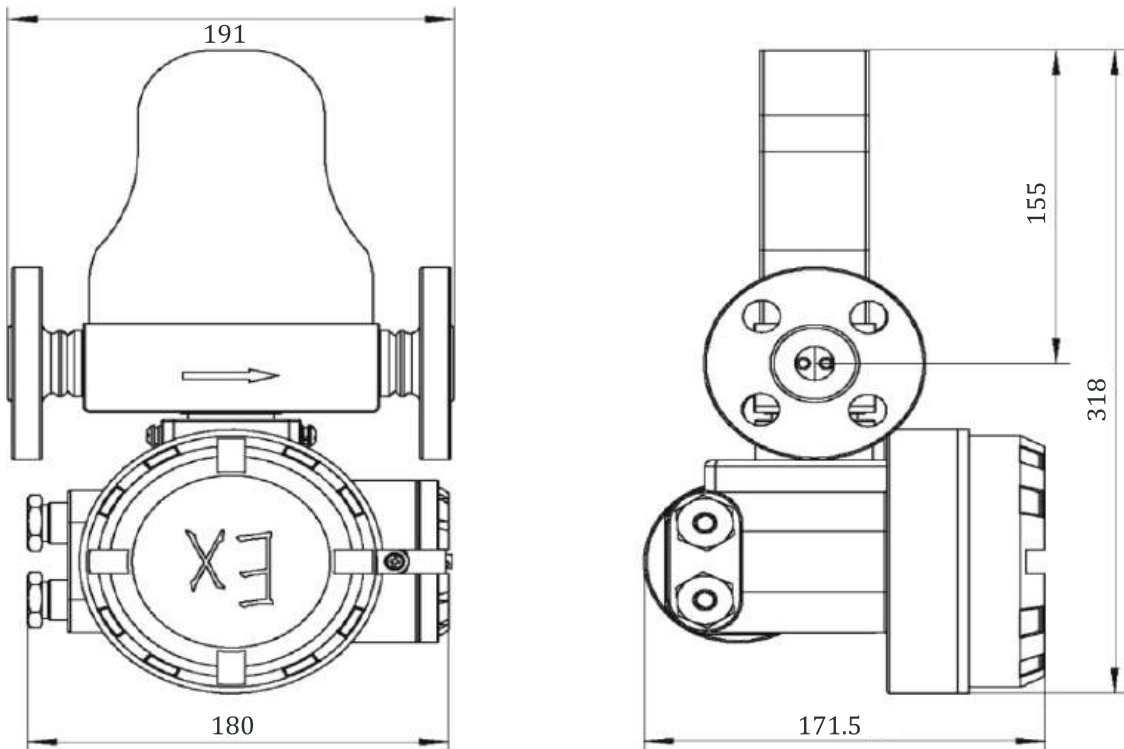

RF3200-25L:

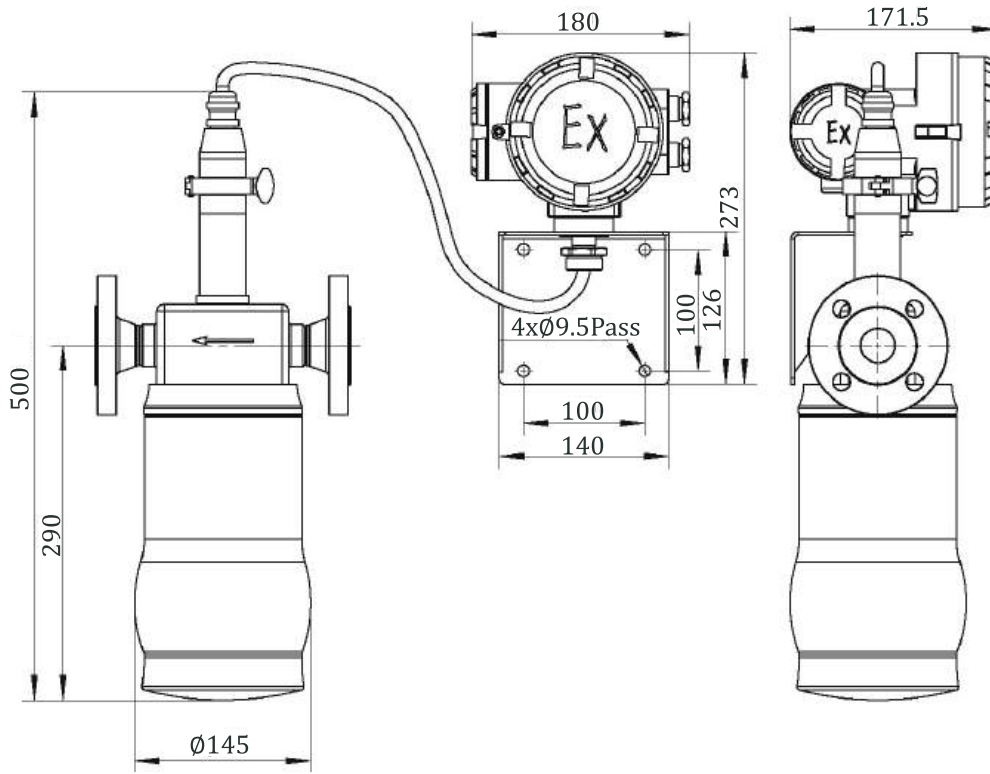

RF3200-15T type:

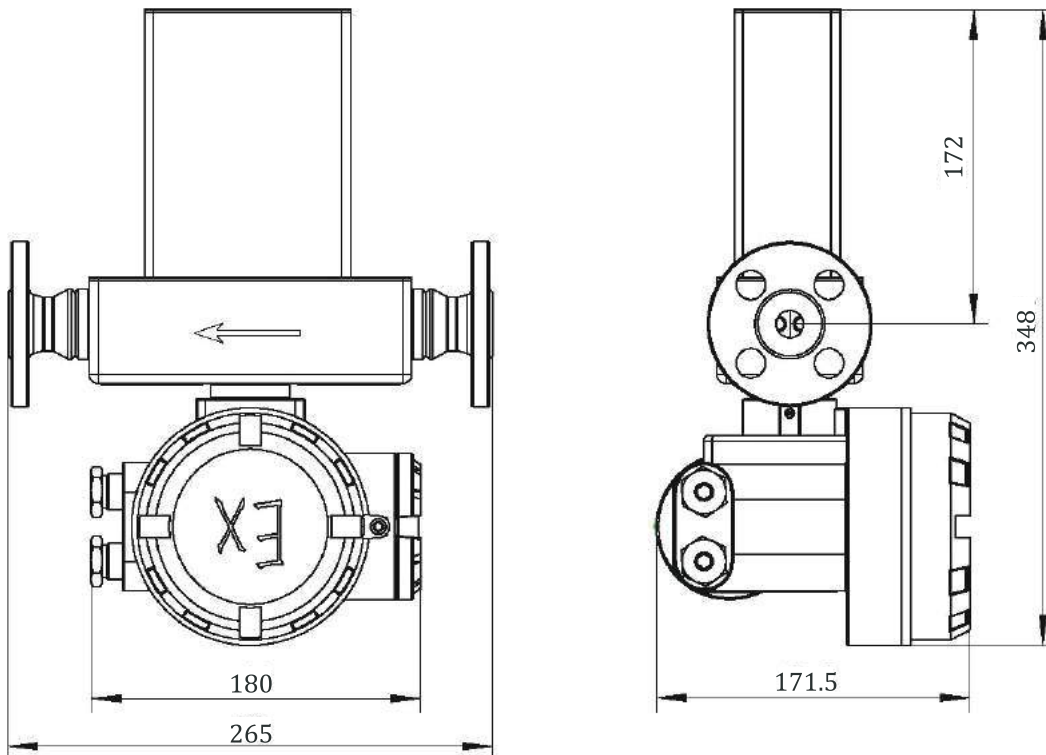

RF3200-25T

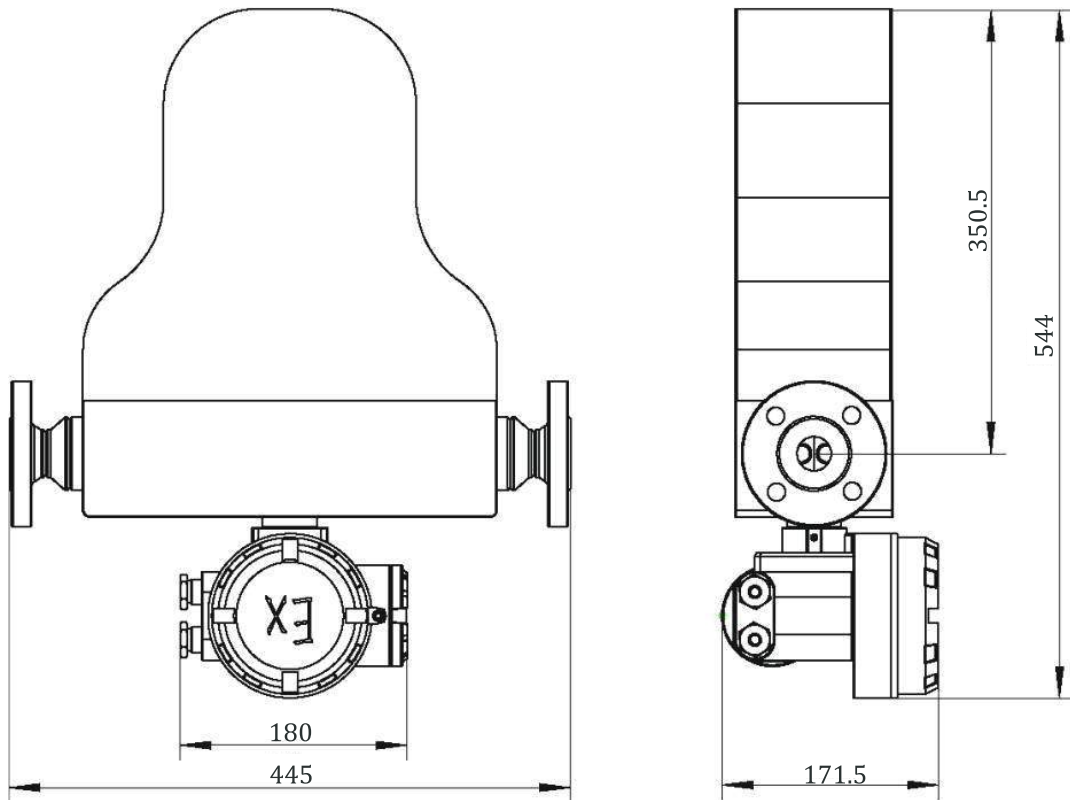

RF3200-50T:

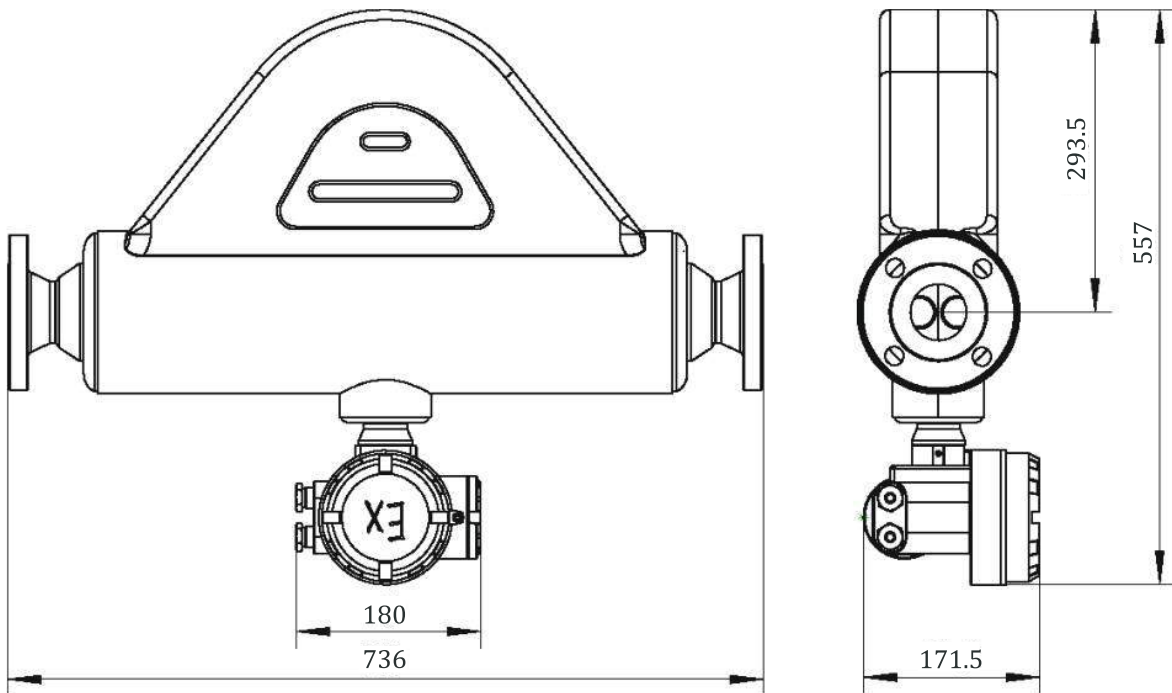

11. Installation

Transmitter Installation: The installation of the transmitter, as for the RF3000 series, it is recommended to be integrated with the sensor in a compact installation (factory default). It can be customized on-site split installation under harsh conditions according to user needs.

Display: The display interface provides users with a better user performance, and provides users with a display function transmitter. Due to electronics are susceptible to ambient temperature, it is recommended to use a non-display transmitter (factory default).

The output signals include: Modbus / RS-485; pulse; 4-20mA current loop.

Electrical connections: The end of the cable to the customer site is a M20 × 1.5 lead.

Application Cautions for Coriolis Mass Flowmeters

If the pressure drop is acceptable, operate a Coriolis mass flowmeter in the upper part of its flow range because operation at low flow rates can degrade accuracy. Note that high viscosity fluids increase the pressure drop across the flowmeter. For liquid flows, make sure that the flowmeter is completely full of liquid. Be especially careful when measuring gas/vapour flow with Coriolis mass flowmeters. Pay special attention to installation because pipe vibration can cause operational problems.

12. Electrical Connection

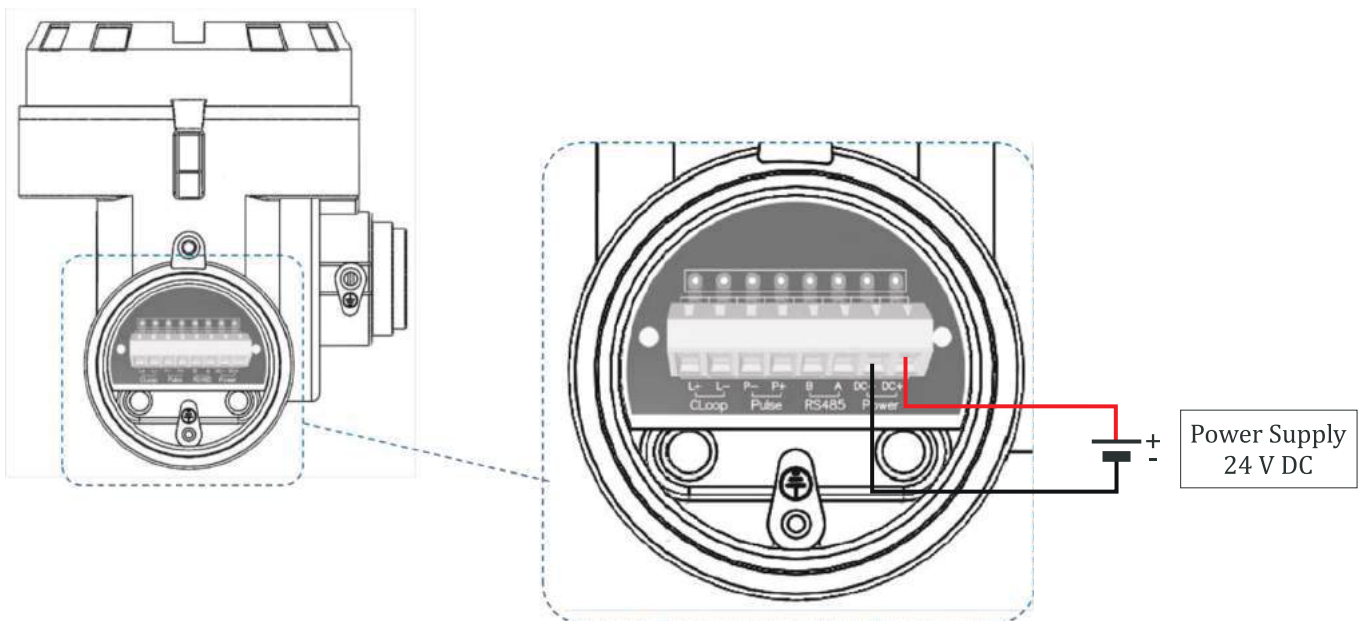

10. Model Selection Table

RF3200		Coriolis Mass Flow Meter											
Code		1	2	3	4	5	6	7	8	9	10	11	12
Application Code													
Normal	T												
Cryogenic	L												
High pressure	P												
Sanitary	W												
CNG/other natural Gases	G												
Nominal Diameter													
DN03	03												
DN04	04												
DN08	08												
DN10	10												
DN15	15												
DN20	20												
DN25	25												
DN40	40												
DN50	50												
DN80	80												
DN100	100												
Nominal Pressure													
1.6MPa	02												
4MPa	04												
6MPa	06												
10MPa	10												
25MPa	25												
35MPa	35												
70MPa	70												
Process Connection													
HG / T 20592 flange	FS												
HG /T20615 flange	F0												
ANSI B 16.5 flange	F1												
ASME B 16.5 flange	F2												
Pipe thread	GS												
NPT thread	NS												
Sanitary Quick coupling (For application code W)	HS												
Alternative option													
C	Test report, material Certificate												
E	English user manual												
Z	Normal standard product (default)												
Approval													
N	None												
I	Intrinsic safe												
D	Flameproof												
Communication Port													
N	None												
M	Modbus / RS-485												
H	HART												
Output													
L	4-20 Ma current loop												
P	Pulse												
Display													
C	With display												
M	Without display												
Mounting Type of Transmitter													
N	Integrated												
S	Remote (with 10m cable)												
Accuracy													
A	0.1 %												
B	0.2%												
C	0.5%												
D	1.0 %												
Material of Measuring Tube													
S	SS316L(Default)												
H	Hastelloy C22												

Example: RF3200-T0402FSSANCLMCE

T - Application Code: Normal

04 - Nominal Diameter: DN04

02 - Nominal pressure : 1.6 MPa

FS - Process connection: HG / T 20592

S - Material of measuring tube: SS316L (Default)

A - Accuracy: 0.1%

N - Mounting type of Transmitter: Integrated

C - Display: With display

L - Output: 4-20 Ma current loop

M - Communication port: Modbus / RS-485

D - Approval: Flameproof

E - Alternative option: English user manual

*For any customisation, contact our sales team

$$\text{Tube frequency} \propto \frac{1}{\text{Density}} \qquad F \propto \frac{1}{\rho}$$

$$\text{Tube twisting} \propto \text{Mass flow rate} \qquad \theta \propto \omega$$

Mass flow measurement

The driving coil inside the sensor ensures that when there is no flow through the tubes then the tube vibrate at a resonant frequency. When there is a flow through the tubes then depends on the flow and its mass of the tubes vibration will change the change in vibration is measured and it is proportional to mass flow.

$$FC = 2 \cdot \Delta m \cdot (V \cdot \omega)$$

Where,

Fc = Coriolis mass flow

Δm = Moving mass flow

ω = Rotational velocity

V = Radial velocity in rotation System.

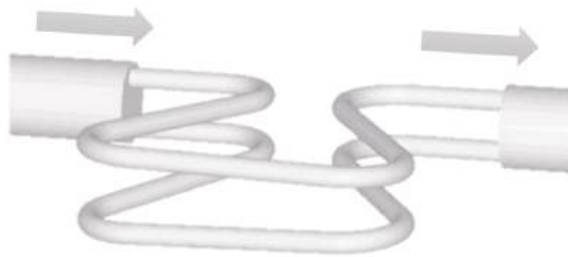

Density measurement

The sensor records the number of times the measuring tube vibrates in one second, which is the vibration frequency. The measuring tube vibrates at its natural frequency. For fluids with different densities, the vibration frequency is different. The more frequent the vibration, the smaller its density.

$$\rho \propto \frac{1}{F^2}$$

Volumetric flow rate measurement

The volumetric flow rate is calculated by measuring the obtained mass flow and density.

$$V = \frac{M}{\rho}$$

Temperature measurement

Temperature is a measured variable that is available as an output, the temperature is also used internal to the sensor to compensate for temperature.

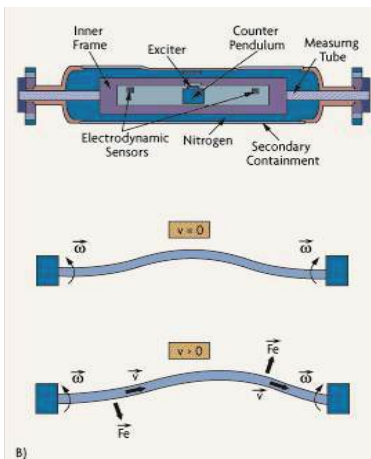

(1) Straight tube, (2) Micro-bend

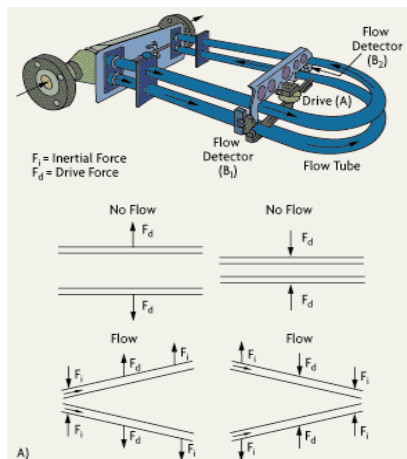

U - Tube

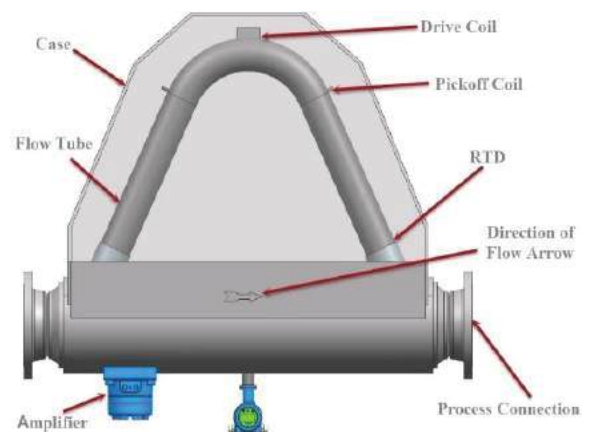

Triangular Tubed

Field Instrumentation Range



Pressure Measurement

- Smart Differential Pressure Transmitter
- Smart Gauge Pressure Transmitter
- Smart Absolute Pressure Transmitter
- Miniature Pressure Transducer without display
- Sanitary Gauge/ Absolute Pressure Transmitter

- Submersible Pressure Transmitter
- Remote Seal Differential P.T. with capillary
- Remote Seal Differential P.T. Direct Mount
- Remote Seal Gauge/Absolute P.T. with capillary
- Remote Seal Gauge/Absolute P.T. Direct Mount



Flow Measurement

- Coriolis Mass Flowmeter
- Thermal Gas Mass Flowmeter
- Positive Displacement Flowmeter
- Electromagnetic Flowmeter
- Vortex Flowmeter

- Turbine Flowmeter
- Variable Area Flowmeter
- Clamp On Ultrasonic Flowmeter
- Inline Ultrasonic Flowmeter
- Portable Ultrasonic Flowmeter



Level Measurement

- RADAR Level Transmitter Horn Antenna
- Compact RADAR Level Transmitter
- RADAR Level Transmitter Sanitary
- RADAR Level Transmitter
- Guided Wave RADAR Level Transmitter
- Guided Wave RADAR Level Transmitter
- RADAR Level Transmitter Lens Antenna

- RADAR Level Transmitter Rod Antenna
- Ultrasonic Level Transmitter
- Microwave Barrier Level Switch
- Admittance Level Switch Series
- Vibrating Rod Level Switch Series
- Tuning Fork Level Switch Series



Temperature Measurement

- Head Mount Temperature Transmitter
- Temperature Transmitter for Sanitary Applications

- DIN Rail Temperature Transmitter
- Field Mount Temperature Transmitter

Rocksensor India Pvt. Ltd.

📍 B -36, Sector 67, Noida, Uttar Pradesh - 201301

For more details, contact us on:

☎ +91 928 948 8117 | +91 1204121469

✉ info@rocksensor.in

🌐 www.rocksensor.in

Global Offices

Global HQ & R&D Centre:
Rocksensor Sàrl, Switzerland

North America:
Rocksensor Automation LLC, USA

APAC:
Rocksensor Automation Co. Ltd., Shanghai

For more updates, follow us on:

in: Rocksensor India

▶: Rocksensor

f: Rocksensor

📷: Rocksensor

🐦: Rocksensor India