

Guided Wave RADAR Level Transmitter

RLT8600



Measuring range upto 30m



Quick Response Time



Process Pressure: (-)1 ~ 400bar



Sensor Housing: IP67 protection

**Product
Datasheet**

ROCKSENSOR AT A GLANCE (ABOUT US)

Rocksensor is one of the global leaders specializing in Process Instrumentation, Research and Development and Designing of Industrial Automation Equipment. We provide highly precise pressure sensors and transmitters, flow metres, level transmitters and temperature transmitters with a prime focus to help our clients efficiently, safely and economically run complex industrial processes.

Rocksensor, headquartered in Switzerland, has its footprint in various geographical regions such as the US, Russia, South Korea, Italy, Germany, Singapore, Malaysia, Morocco, China, Taiwan, Australia, UAE, Brazil and India. Our clients come from some of the major industries such as Oil and Gas, Petrochemicals, Pharmaceuticals, FMCG, Automobiles, Water, Cement, Metal & Mining, and mainly from the Power Industry like Nuclear, Thermal, Hydro, and Solar.

Rocksensor deals in a wide range of highly accurate industrial automation instruments ensuring that even the complex industrial processes happen efficiently.

To fulfill the needs of our clients we make sure that our instruments work in even the harsh environmental conditions offering accurate recordings and communication.

We, at Rocksensor, believe in creating bonds that last a lifetime and create a success story for each and every client. Rocksensor aims to achieve a perfect fit in the global market landscape and establish our footprints across the globe.



CONTENTS

1. Introduction	3
2. Area of Application	3
3. Feature and Benefit	3
4. Function	3
5. Technical Specifications	3
6. Material	3
7. Housing Version	3
8. Electrical Connections	4
9. Operation	4
10. Dimensions	4
11. Model Selection Table	5

KEY APPLICATION INDUSTRIES

- Oil and Gas sector
- Cement
- Metal
- Pulp and Paper
- Agriculture
- Textiles
- Chemicals
- Power
- Water
- Pharmaceutical
- Fertilizer
- Plastics and HVAC

1. Introduction

RLT8600 Radar Level Transmitter is suitable for continuous Level measurement of Non-aggressive Liquids under high Pressure & high Temperature conditions.

2. Area of application

The RLT8600 is a radar sensor for continuous level measurement of non-aggressive liquids under high pressure and high temperature conditions. The sensor delivers precise and reliable measured values even in applications with steam, buildup, foam generation or condensation.

3. Feature and Benefit

- Twin-chips: With two chips, RLT8600 achieves higher processing ability.
- Multi-Track: Due to new Multi-Track wave tracking algorithm, RLT8600 gets highest reliability.
- Waves Memo: With wave management function. To help understand abnormal output, RLT8600 stores wave automatically.

4. Function

The RLT8600 guided radar transmitter is designed for continuous level measuring of conductive or nonconductive liquids. The RLT8600 is a "downward-looking" measuring system that functions according to the TDR principle (Time Domain Reflectometry). High frequency microwave impulses are guided along a steel cable/ rod. When they reach the product surface, the microwave pulses are reflected & received by the processing electronics. Level distance is directly proportional to the flight time of the pulse.

5. Technical Specifications

Measuring Range (-Cable Probe/ -Rod Probe/ -Coax Probe)	0 ~ 30m/ 0 ~ 6m/ 0 ~ 3m
Sample Frequency	16Hz
Response Time	<2s
Resolution	1mm
Deviation	±3mm
Repeatability	±1.5mm
Frequency	100MHz ~ 1.8GHz
Ambient Temperature	(-)40°C ~ 70°C
Process Temperature	(-)40°C ~ 450°C
Process Pressure	(-)1 ~ 400bar
Protect Level	IP67
Transmitter Housing	Single Chamber (Std.)/ Double Chamber (optional)
Antenna Material	SS316 (Std.)

6. Material

The wetted parts of the instrument are made of 316L stainless steel or ceramic. The process seal is made of graphite.

7. Housing Version

The housings are available as single chamber version and double chamber version in stainless steel or aluminium. They are available with protection ratings up to IP 67 (1 bar).

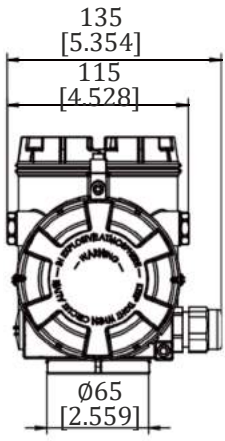

Double Chamber Housing

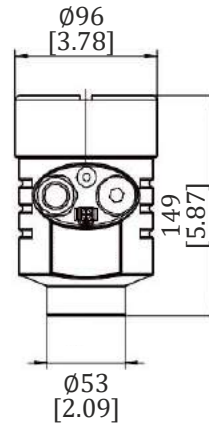
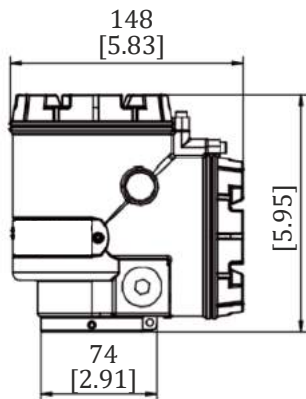

Single Chamber Housing

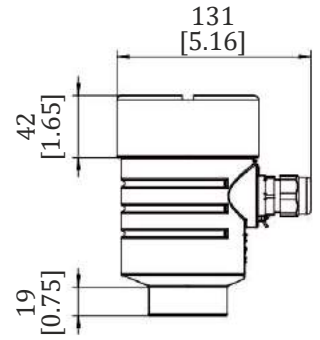

8. Electrical Connection

The instruments are available in different electronics versions. 4 ~ 20 mA/HART in two and four-wire version with 24 VDC and four-wire with 220VAC.

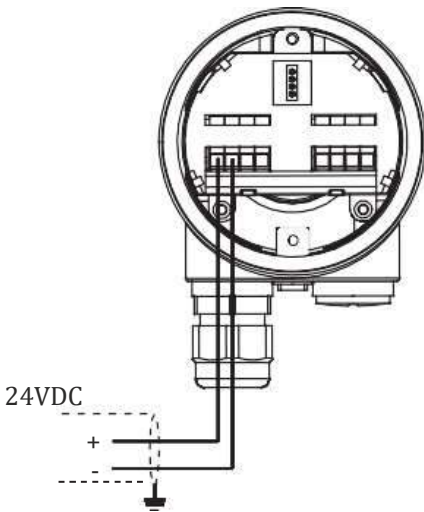

24V DC.Two-wire

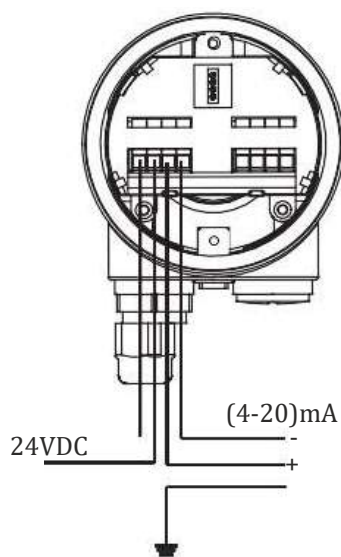

24V DC.Four-wire

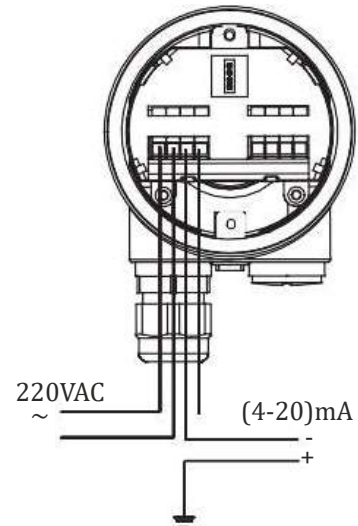

220V AC.Four-wire

9. Operation

The adjustment of the instrument is carried out via the LCD display, tank side display, tank side hub and HART communicator.

10. Dimensions

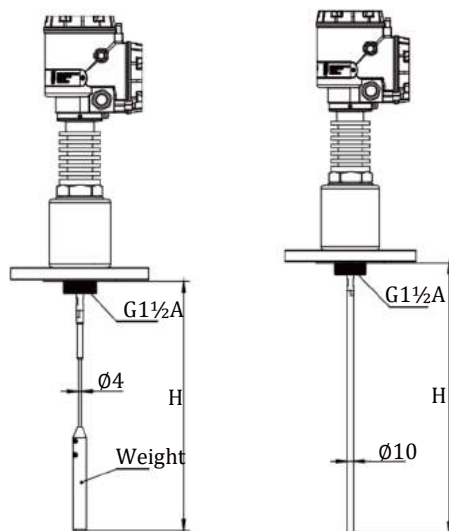

1 Single cable probe

2 Single rod probe

11. Model Selection Table

RLT8600		Radar Level Transmitter									
Code		1	2	3	4	5	6	7	8	9	10
Language											
English	A										
Approval											
Standard	XX										
Ex Ia TIC 16 Ga	CX										
Ex dia [iaGa]IIC T6/ T2 Gb	DX										
Ex iaD tD A21 IP67 T80/T290°C	EX										
Antenna Version/ Material											
Ø2mm probe cable+weight/SS316	B										
Ø4mm probe cable+weight/SS316	A										
Ø10mm probe rod/ Ss316	E										
Ø16mm probe rod/ Ss316	F										
Ø4mm double SS probe cable + weight/ Ss316	G										
Coaxial waveguide Ø42mm/SS316	P										
Customized	T										
Process Fitting											
Thread G1½A	TI										
Thread 1½ NPT	NP										
Flange DN50	DD										
Flange DN80	DF										
Customized	TT										
LCD Display											
X	Without display										
A	With display										
Cable Entry / Cable Gland/ Connecting Cable											
M	M20x1.5/ with/ without										
N	½NPT/ without/ without										
Housing/ Protection											
A	Single chamber/ Aluminum/ IP67										
B	Double chamber/ Aluminum/ IP67										
W	Double chamber/ Ss316/ IP67										
Auxiliary Accessories											
X	Without										
T	Tank side monitor entry										
Electronics											
H	Two-wire 4-20mA/HART; 24VDC										
B	Four wire 4-20mA/HART; 220VAC										
I	Four wire 4-20mA/HART; 24VDC										
W	Wireless; GPRS; Wireless C Mesh										
T	Customized										
Process Seal / Temperature											
A	Graphite ceramics/ (-)196 ~ 280°C										
F	Graphite ceramics/ -196 ~ 400°C										
L	Graphite ceramics/ -196 ~ 450°C										
T	Customized										

Example: RLT8100-AXXB TIAWTANA

A - Language: English

XX - Approval: Standard

B - Antenna Version/ Material: Ø2mm probe cable+weight/ Ss316

TI - Process Fitting: Thread G1½A

A - Process Seal/ Temperature: VITON Fluorine rubber/ (-)40 ~ 80°C

W - Electronics: Wireless; GPRS; Wireless C Mesh

T - Auxiliary Accessories: Tank Side Monitor Entry

A - Housing/ Protection: Single Chamber/ Aluminum / IP67

N - Cable Entry / Cable Gland/ Connecting Cable : ½NPT/ Without/ Without

A - LCD Display: With Display

*For any customisation, contact our sales team



ROCKSENSOR™

Sensing Beyond the Vision

Field Instrumentation Range



Pressure Measurement

- Smart Differential Pressure Transmitter
- Smart Gauge Pressure Transmitter
- Smart Absolute Pressure Transmitter
- Miniature Pressure Transducer without display
- Sanitary Gauge/ Absolute Pressure Transmitter
- Submersible Pressure Transmitter
- Remote Seal Differential P.T. with capillary
- Remote Seal Differential P.T. Direct Mount
- Remote Seal Gauge/Absolute P.T. with capillary
- Remote Seal Gauge/Absolute P.T. Direct Mount



Flow Measurement

- Coriolis Mass Flowmeter
- Thermal Gas Mass Flowmeter
- Positive Displacement Flowmeter
- Electromagnetic Flowmeter
- Vortex Flowmeter
- Turbine Flowmeter
- Variable Area Flowmeter
- Clamp On Ultrasonic Flowmeter
- Inline Ultrasonic Flowmeter
- Portable Ultrasonic Flowmeter



Level Measurement

- RADAR Level Transmitter Horn Antenna
- Compact RADAR Level Transmitter
- RADAR Level Transmitter Sanitary
- RADAR Level Transmitter
- Guided Wave RADAR Level Transmitter
- Guided Wave RADAR Level Transmitter
- RADAR Level Transmitter Lens Antenna
- RADAR Level Transmitter Rod Antenna
- Ultrasonic Level Transmitter
- Microwave Barrier Level Switch
- Admittance Level Switch Series
- Vibrating Rod Level Switch Series
- Tuning Fork Level Switch Series



Temperature Measurement

- Head Mount Temperature Transmitter
- Temperature Transmitter for Sanitary Applications
- DIN Rail Temperature Transmitter
- Field Mount Temperature Transmitter

Rocksensor India Pvt. Ltd.

📍 : B -36, Sector 67, Noida, Uttar Pradesh - 201301

For more details, contact us on:

☎ +91 928 948 8117 | +91 1204121469

✉ : info@rocksensor.in

🌐 : www.rocksensor.in

Global Offices

Global HQ & R&D Centre:
Rocksensor Sàrl, Switzerland

North America:
Rocksensor Automation LLC, USA

APAC:
Rocksensor Automation Co. Ltd., Shanghai

For more updates, follow us on:

in: [Rocksensor India](#)

yt: [Rocksensor](#)

f: [Rocksensor](#)

ig: [Rocksensor](#)

tw: [Rocksensor India](#)