

Thermal Mass Flow Meter

RF3700



Integral/ Remote Structure



High Accuracy: $\pm 1\%$



Velocity: 0.1 ~ 100Nm/s



IP65 Enclosure Protection

**Product
Datasheet**

ROCKSENSOR AT A GLANCE (ABOUT US)

Rocksensor is one of the global leaders specializing in Process Instrumentation, Research and Development and Designing of Industrial Automation Equipment. We provide highly precise pressure sensors and transmitters, flow metres, level transmitters and temperature transmitters with a prime focus to help our clients efficiently, safely and economically run complex industrial processes.

Rocksensor, headquartered in Switzerland, has its footprint in various geographical regions such as the US, Russia, South Korea, Italy, Germany, Singapore, Malaysia, Morocco, China, Taiwan, Australia, UAE, Brazil and India. Our clients come from some of the major industries such as Oil and Gas, Petrochemicals, Pharmaceuticals, FMCG, Automobiles, Water, Cement, Metal & Mining, and mainly from the Power Industry like Nuclear, Thermal, Hydro, and Solar.

Rocksensor deals in a wide range of highly accurate industrial automation instruments ensuring that even the complex industrial processes happen efficiently.

To fulfill the needs of our clients we make sure that our instruments work in even the harsh environmental conditions offering accurate recordings and communication.

We, at Rocksensor, believe in creating bonds that last a lifetime and create a success story for each and every client. Rocksensor aims to achieve a perfect fit in the global market landscape and establish our footprints across the globe.



CONTENTS

1. Introduction	4
2. Working Principle	4
3. Features	4
4. Key Applications	4
5. Identification	5
6. Technical Specifications	5
7. Dimensional Drawings	6-7
7.1 In-Line Type	6
7.2 Flange Type	6
7.3 Insertion Type	7
8. Flow & Velocity Table	7
9. Model Selection Table	8
Appendix 1: The Density & Conversion Coefficient of Common Gas	9-10
Appendix 2: Upper Range Value of Common Gases	10

KEY APPLICATION INDUSTRIES

- Oil and Gas sector
- Cement
- Metal
- Pulp and Paper
- Agriculture
- Textiles
- Chemicals
- Power
- Water
- Pharmaceutical
- Fertilizer
- Plastics and HVAC

1. Introduction

Thermal mass flow meters, also known as thermal dispersion or immersible mass flow meters comprise a family of instruments for the measurement of the total mass flow rate of a fluid, primarily gases, flowing through closed conduits. Thermal gas mass flow meter is designed on the basis of thermal dispersion, and adopts method of constant differential temperature to measure gas flow. It has advantages of small size, easy installation, high reliability and high accuracy, etc.

2. Working Principle

Thermal flow meters use the thermal properties of the gases to measure the flow of a gas flowing in a pipe or duct. The flowmeter contains two platinum resistance temperature sensors. The thermal flow meter operates by monitoring the cooling effect of a gas stream as it passes over a heated sensor. Gas flowing through the sensing section passes over two sensors one of which is used conventionally as a temperature sensor, while other is used as a heater. The temperature sensor monitors the actual process values while the heater is maintained at a constant differential temperature. The greater the gas velocity, the greater the cooling effect and power required to maintain the differential temperature. The measurement of heater power is therefore a measurement of the gas mass flow rate.

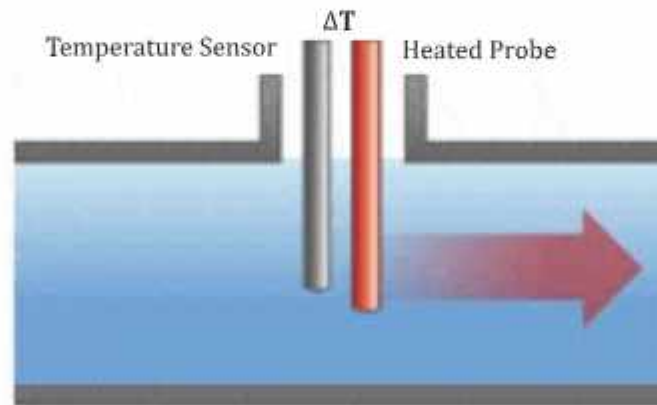

$$m = \frac{Kq}{(C_p(T_2 - T_1))}$$

The mass flow (m) is calculated on the basis of the measured temperature difference ($T_2 - T_1$), the meter coefficient (K), the electric heat rate (q), and the specific heat of the fluid (C_p).

3. Features

- Compact size, easy installation, high reliability and high accuracy
- Can be used for gas leak detection
- Reference accuracy up to $\pm 1\%$
- Configuration with RS485 or HART Interfaces
- Available in Insertion and Flange Connection Type
- No need for temperature or pressure compensation
- Good vibration resistance, no moving parts
- Standard 4-20 mADC Analog/ Pulse Output
- Suitable for medium temperature up to 150°C

4. Key Applications

- Compressed Air
- Natural gas in boiler rooms or dryers
- Carbon dioxide gas in breweries
- Biogas & aeration in sewage treatment plants
- Generating Gases (e.g. Argon, Nitrogen, Carbon Dioxide, Helium, Oxygen)
- Gas leak detection

5. Identification

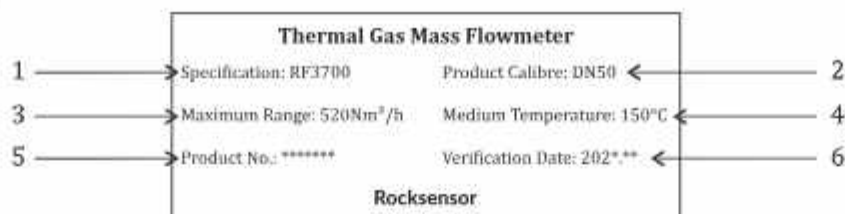

1. Specifications

2. Line Size

3. Maximum Range

4. Medium Temperature

5. Product Serial Number

6. Verification Date

6. Technical Specifications

Parameters	Details	
Measuring Medium	Gas (Except Acetylene & Steam)	
Velocity	0.1-100Nm/s	
Accuracy	±2.5%/ ±1.5% Reading (Insertion)	±1% Reading (Flange)
Response Time	1s	
Output	4-20mA(optoelectronic isolation,maximum load 500Ω),Pulse RS485 (optoelectronic isolation) & HART	
Power Supply	Compact : 24VDC or 220VAC; Power Consumption: ≤18W Remote Type : 220VAC; Power Consumption : ≤19W	
Working Pressure	Insertion type ≤1.6Mpa	
	Flange type ≤4.0Mpa	
	Tri-clamps ≤1.6MPa	
	Threads ≤4.0Mpa	
T _{ambient}	(-)20°C ~ 50°C	
T _{medium}	(-)20°C ~ 150°C	
Transmitter Housing	Die-cast Aluminium	
Cable Entry	M20*1.5 standard, 1/2"NPT Optional	
Ingress Protection	IP65 / Explosion Proof	
Display	4 Digit LCD, Mass Flow, Volume Flow, Flow Totalizer, etc.	
Flow Units	Nm ³ /h, Nm ³ /min, kg/h, kg/min or more	
Alarm Output	2 relays, 3A/250VAC, 3A/30VDC	
Structure Type	Remote or Integral	
Cable Length (Remote type)	Standard 10 meters	
Pipe Material	Carbon Steel, Stainless Steel, Plastic, etc.	
Insertion type	Size : DN32~DN4000mm	
	Rod, Valve, Sensor material : Standard SS304 / SS316L / SS316*	
Flange type	Size : DN10~DN300 (Can be designed for size above DN300)	
	Flange Standard : ANSI, DIN	
	Tube materials : Standard SS304/SS316L/ SS316* Sensor materials : Standard SS304/SS316L / SS316* Flange materials : Standard SS304/SS316L/ SS316*	
Tri-clamp type	Size : DN10~DN100	
	Tube materials : Standard SS304/ SS316 Sensor materials : Standard SS316	
Thread type	Size : DN10~DN100	
	Tube materials : Standard SS304/SS316L/ SS316* Sensor materials : Standard SS304/SS316L / SS316*	
*SS316 material will be available upon factory consultation and confirmation.		

7. Dimensional Drawings

7.1 In-Line type

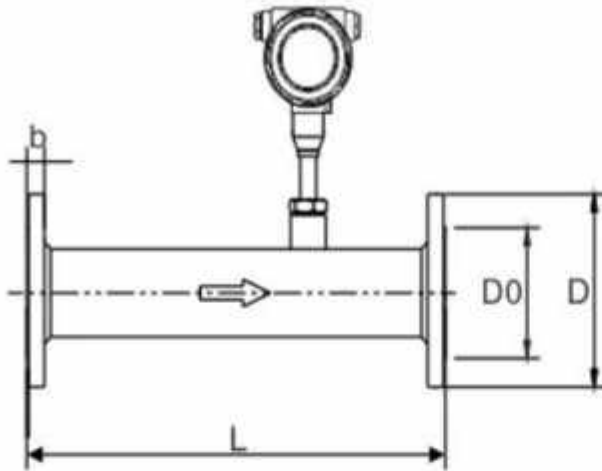

Figure 1

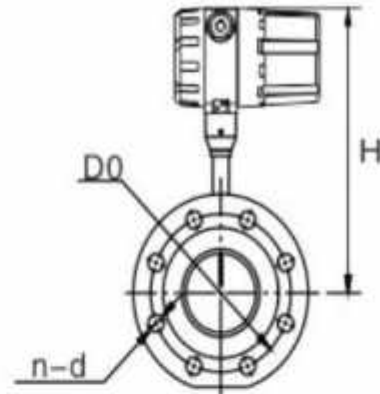

Figure 2



Integrated Type



Remote Type

7.2 Flange Type

Nominal Diameter DN	Pressure Rating MPa	Length of Shape L	Shape Width L	D0 Diameter of Central Hole	D of Flange Diameter r	Screw Hole S n-d	Thread Specifications	Flange Thickness sb
25	1.6	305	268	85	115	4*14	M12	16
32	1.6	310	272	100	140	4*18	M16	18
40	1.6	320	275	110	150	4*18	M16	18
50	1.6	396	280	125	165	4*18	M16	20
65	1.6	410	288	145	185	4*18	M16	20
80	1.6	420	296	160	200	8*18	M16	20
100	1.6	457	308	180	220	8*18	M16	22
125	1.6	500	320	210	250	8*18	M16	22
150	1.6	500	335	240	280	8*22	M20	24

7.3 Insertion type

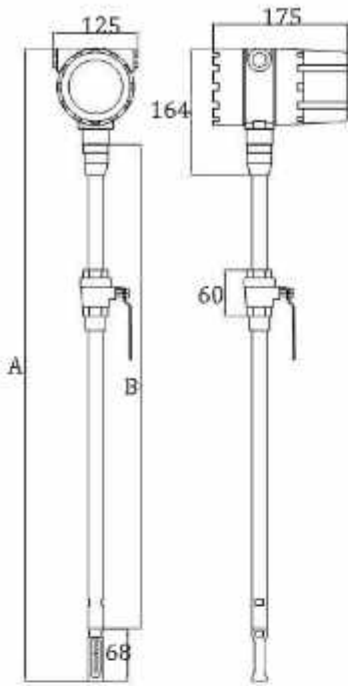

Integrated Type



Remote Type

8. Flow & Velocity Table

Size	Min Velocity (Nm/S)	Max Velocity (Nm/s)	Min Flow (Nm ³ /h)	Max Flow (Nm ³ /h)
10	0.1	100	0.028274334	28.27433385
15	0.1	100	0.063617251	63.61725116
20	0.1	100	0.113097335	113.0973354
25	0.1	100	0.176714587	176.7145866
32	0.1	100	0.289529179	289.5291786
40	0.1	100	0.452389342	452.3893416
50	0.1	100	0.706858346	706.8583463
65	0.1	100	1.194590605	1194.590605
80	0.1	100	1.809557366	1809.557366
100	0.1	100	2.827433385	2827.433385
125	0.1	100	4.417864664	4417.864664
150	0.1	100	6.361725116	6361.725116
200	0.1	100	11.30973354	11309.73354
250	0.1	100	17.67145866	17671.45866
300	0.1	100	25.44690047	25446.90047
350	0.1	100	34.63605897	34636.05897
400	0.1	100	45.23893416	45238.93416
450	0.1	100	57.25552605	57255.52605
500	0.1	100	70.68583463	70685.83463
600	0.1	100	101.7876019	101787.6019
700	0.1	100	138.5442359	138544.2359
800	0.1	100	180.9557366	180955.7366
900	0.1	100	229.0221042	229022.1042
1000	0.1	100	282.7433385	282743.3385

9. Model Selection Table

RF3700 Thermal Mass Flow Meter	
Code	1 2 3 4 5 6 7 8 9 10 11
Line Size (DN)	
DN10 ~ DN4000	Standard Line Sizes
Structure	
Integral	C
Remote	R
Sensor Type	
Insertion	I
Flange	F
Triclamp	C
Thread	S
Body Material	
SS304	S1
SS316L	S2
SS316*	S3
<small>*Body Material includes tube and sensor material for sensor type flange/Thread/Triclamp</small>	
<small>*Body Material includes Rod, Valve and Sensor material for insertion type</small>	
Flange Connection	
DIN PN16/PN25/PN40	D**
A15 :ANSI 150#, A30: ANSI 300#	A**
None (For Thread, Insertion & Triclamp Type)	N
Flange Materials	
SS304	S1
SS316L	S2
SS316*	S3
None	N
Explosion Proof Option	
N	None
E	Flameproof Exd
Signal Output	
RS	4-20 mA + Pulse + RS485
HT	4-20 mA + Pulse + HART
Power Supply	
AC	AC 85-250V
DC	DC 20-36V
Working Temperature	
T1	(-)20°C ~ 150°C
Working Pressure	
16	1.6 MPa
25	2.5 MPa
40	4.0 MPa

Example: RF3700-30CIS1DS216T1ACRSE

RF700 - Thermal Mass Flowmeter

30 - Line Size (DN) : DN30

C - Structure : Integral

I - Sensor Type : Insertion

S1 - Body Material : SS304

D - Flange Connection : DIN PN16/PN25/PN40

S2 - Flange Materials : SS316L

16 - Working Pressure : 1.6 MPa

T1 - Working Temperature : (-)20°C ~ 150°C

AC - Power Supply : AC 85-250V

RS - Signal Output : 4-20 mA + Pulse + RS485

E - Explosion Proof Option : Flameproof Exd

Note: *SS316 material will be available upon factory consultation and confirmation

*For any customisation, contact our sales team

Appendix 1: The Density and Conversion Coefficient of Common Gas

According to different gas on site, the calibration in lab translates the flow rate of actual gas on site into flow of air & then begins to calibrate the flow rate at present. Therefore, when using the meter on site, the meter displays mass flow/ volume flow of actual gas. When converting the flow rate of gas into flow rate of air, there is a conversion coefficient table of different gases.

Sr. No.	Gas Name	Specific Heat (Cal/g/°C)	Density (g/l, 0°C)	Conversion Coefficient
1.	Air	0.24	1.2048	1.0000
2.	Argon (Ar)	0.125	1.6605	1.4066
3.	Arsine (AsH ₃)	0.1168	3.478	0.6690
4.	Boron Tribromide (BBr ₃)	0.0647	11.18	0.3758
5.	Boron Trichloride (BCl ₃)	0.1217	5.227	0.4274
6.	Boron Trifluoride (BF ₃)	0.1779	3.025	0.5050
7.	Borane (B ₂ H ₆)	0.502	1.235	0.4384
8.	Carbon Tetrachloride (CCl ₄)	0.1297	6.86	0.3052
9.	Carbon Tetrafluoride (CF ₄)	0.1659	3.9636	0.4255
10.	Methane (CH ₄)	0.5318	0.715	0.7147
11.	Acetylene (C ₂ H ₂)	0.4049	1.162	0.5775
12.	Ethylene (C ₂ H ₄)	0.3658	1.251	0.5944
13.	Ethane (C ₂ H ₆)	0.4241	1.342	0.4781
14.	Allylene (C ₃ H ₄)	0.3633	1.787	0.4185
15.	Propylene (C ₃ H ₆)	0.3659	1.877	0.3956
16.	Propane (C ₃ H ₈)	0.399	1.967	0.3459
17.	Butyne (C ₄ H ₆)	0.3515	2.413	0.3201
18.	Butene (C ₄ H ₈)	0.3723	2.503	0.2923
19.	Butane (C ₄ H ₁₀)	0.413	2.593	0.2535
20.	Pentane (C ₅ H ₁₂)	0.3916	3.219	0.2157
21.	Carbinol (CH ₃ OH)	0.3277	1.43	0.5805
22.	Ethanol (C ₂ H ₅ O)	0.3398	2.055	0.3897
23.	Trichloroethane (C ₂ H ₃ Cl ₃)	0.1654	5.95	0.2763
24.	Carbon Monoxide (CO)	0.2488	1.25	0.9940
25.	Carbon Dioxide (CO ₂)	0.2017	1.964	0.7326
26.	Cyanide (C ₂ N ₂)	0.2608	2.322	0.4493
27.	Chlorine (Cl ₂)	0.1145	3.163	0.8529
28.	Deuterium (D ₂)	1.7325	0.1798	0.9921
29.	Fluoride (F ₂)	0.197	1.695	0.9255
30.	Germanium Tetrachloride (GeCl ₄)	0.1072	9.565	0.2654
31.	Germane (GeH ₄)	0.1405	3.418	0.5656
32.	Hydrogen (H ₂)	3.4224	0.0899	1.0040
33.	Hydrogen Bromide (HBr)	0.0861	3.61	0.9940
34.	Hydrogen Chloride (HCl)	0.1911	1.627	0.9940
35.	Hydrogen Fluoride (HF)	0.3482	0.893	0.9940
36.	Hydrogen Iodide (HI)	0.0545	5.707	0.9930
37.	Hydrogen Sulphide (H ₂ S)	0.2278	1.52	0.8390
38.	Helium (He)	1.2418	0.1786	1.4066
39.	Krypton (Kr)	0.0593	3.739	1.4066
40.	Nitrogen (N ₂)	0.2486	1.25	0.9940
41.	Neon (Ne)	0.2464	0.9	1.4066
42.	Ammonia (NH ₃)	0.5005	0.76	0.7147
43.	Nitric Oxide (NO)	0.2378	1.339	0.9702
44.	Nitrogen Dioxide (NO ₂)	0.1923	2.052	0.7366
45.	Nitrous Oxide (N ₂ O)	0.2098	1.964	0.7048
46.	Oxygen (O ₂)	0.2196	1.427	0.9861
47.	Phosphorous Trichloride (PCl ₃)	0.1247	6.127	0.3559

48.	Phosphorane (PH ₃)	0.261	1.517	0.6869
49.	Phosphorous Pentafluoride (PF ₅)	0.1611	5.62	0.3002
50.	Phosphorous Oxychloride (POCl ₃)	0.1324	6.845	0.3002
51.	Silicon Tetrachloride (SiCl ₄)	0.127	7.5847	0.2823
52.	Silicon Fluoride (SiF ₄)	0.1692	4.643	0.3817
53.	Silane (SiH ₄)	0.3189	1.433	0.5954
54.	Dichlorosilane (SiH ₂ Cl ₂)	0.1472	4.506	0.4095
55.	Trichlorosilane (SiHCl ₃)	0.1332	6.043	0.3380
56.	Sulphur Hexafluoride (SF ₆)	0.1588	6.516	0.2624
57.	Sulphur Dioxide (SO ₂)	0.1489	2.858	0.6829
58.	Titanium Tetrachloride (TiCl ₄)	0.1572	8.465	0.2048
59.	Tungsten Hexafluoride (WF ₆)	0.0956	13.29	0.2137
60.	Xenon (Xe)	0.0379	5.858	1.4066

Appendix 2: Upper Range Value of Common Gases

(Unit: Nm³/h. The following table can be extended)

Nominal Diameter (mm)	Air	Nitrogen (N ₂)	Oxygen (O ₂)	Hydrogen (H ₂)
15	65	65	32	10
25	175	175	89	28
32	290	290	144	45
40	450	450	226	70
50	700	700	352	110
65	1200	1200	600	185
80	1800	1800	900	280
100	2800	2800	1420	470
125	4400	4400	2210	700
150	6300	6300	3200	940
200	10000	10000	5650	1880
250	17000	17000	8830	2820
300	25000	25000	12720	4060
400	45000	45000	22608	7200
500	70000	70000	35325	11280
600	100000	100000	50638	16300
700	135000	135000	69240	22100
800	180000	180000	90432	29000
900	220000	220000	114500	37807
1000	280000	280000	141300	49120
1200	400000	400000	203480	71972
1500	600000	600000	318000	101520
2000	700000	700000	565200	180480

- The above flowrate is in standard condition at 20°C Temperature and 101.325 kPa Pressure.
- The other flowrate unit options are: Nm³/h, Nm³/min, L/h, L/min, t/h, t/min, kg/h or kg/min.
- Equation for flowrate correlating the Working Flowrate and Standard Flowrate:

$$Q_s = \frac{0.101325 + p}{0.101325} \times \frac{273.15 + 20}{273.15 + t} \times Q_n$$

Q_s = Flowrate in standard condition (Nm³/h)

Q_n = Flow rate in working condition (m³/h).

t = Medium temperature in working condition (°C)

p = Medium pressure in working condition (Gauge pressure, kPa)

Field Instrumentation Range



Pressure Measurement

- Smart Differential Pressure Transmitter
- Smart Gauge Pressure Transmitter
- Smart Absolute Pressure Transmitter
- Miniature Pressure Transducer without display
- Sanitary Gauge/ Absolute Pressure Transmitter

- Submersible Pressure Transmitter
- Remote Seal Differential P.T. with capillary
- Remote Seal Differential P.T. Direct Mount
- Remote Seal Gauge/Absolute P.T. with capillary
- Remote Seal Gauge/Absolute P.T. Direct Mount



Flow Measurement

- Coriolis Mass Flowmeter
- Thermal Gas Mass Flowmeter
- Positive Displacement Flowmeter
- Electromagnetic Flowmeter
- Vortex Flowmeter

- Turbine Flowmeter
- Variable Area Flowmeter
- Clamp On Ultrasonic Flowmeter
- Inline Ultrasonic Flowmeter
- Portable Ultrasonic Flowmeter



Level Measurement

- RADAR Level Transmitter Horn Antenna
- Compact RADAR Level Transmitter
- RADAR Level Transmitter Sanitary
- RADAR Level Transmitter
- Guided Wave RADAR Level Transmitter
- Guided Wave RADAR Level Transmitter
- RADAR Level Transmitter Lens Antenna

- RADAR Level Transmitter Rod Antenna
- Ultrasonic Level Transmitter
- Microwave Barrier Level Switch
- Admittance Level Switch Series
- Vibrating Rod Level Switch Series
- Tuning Fork Level Switch Series



Temperature Measurement

- Head Mount Temperature Transmitter
- Temperature Transmitter for Sanitary Applications

- DIN Rail Temperature Transmitter
- Field Mount Temperature Transmitter

Rocksensor India Pvt. Ltd.

📍 B -36, Sector 67, Noida, Uttar Pradesh - 201301

For more details, contact us on:

☎ +91 928 948 8117 | +91 1204121469

✉ info@rocksensor.in

🌐 www.rocksensor.in

Global Offices

Global HQ & R&D Centre:
 Rocksensor Sàrl, Switzerland

North America:
 Rocksensor Automation LLC, USA

APAC:
 Rocksensor Automation Co. Ltd., Shanghai

For more updates, follow us on:

in: Rocksensor India

yt: Rocksensor

f: Rocksensor

ig: Rocksensor

tw: Rocksensor India